



# **STRAIGHTENER / RAPID-ROLL OPERATING INSTRUCTIONS**

## **MODELS**

**SA3 - SD WITH COMPACT CONTROL**

*(5-07)*

# TABLE OF CONTENTS

---

<b>Straightener Layout Sheet SBX .....</b>	<b>pg. 3</b>
<b>Straightener Layout Sheet SCX.....</b>	<b>pg. 4</b>
<b>Platen Adjustment Bulletin .....</b>	<b>pg. 5</b>
<b>Specifications .....</b>	<b>pg. 6</b>
<b>Installation.....</b>	<b>pg. 7</b>
<b>Start-Up Procedure .....</b>	<b>pg. 8</b>
<b>Electrical Controls Layout .....</b>	<b>pg. 9-10</b>
<b>Dancer Arm Adjustment Explanation .....</b>	<b>pg. 11</b>
<b>Standard and Optional Components .....</b>	<b>pg. 12</b>
<b>Operations.....</b>	<b>pg. 13</b>
<b>Maintenance .....</b>	<b>pg. 13</b>
<b>Troubleshooting Guide .....</b>	<b>pg. 14</b>
<b>Taut Stock Explanation.....</b>	<b>pg. 15</b>
<b>RAMM Board Explanation.....</b>	<b>pg. 16-19</b>
<b>Warranty.....</b>	<b>pg. 20</b>
<b>Electrical Schematics .....</b>	<b>pg. 21-23</b>
<b>Mechanical Parts List SBX .....</b>	<b>pg. 24-27</b>
<b>Mechanical Parts List SCX.....</b>	<b>pg. 28-33</b>
<b>Typical Stamping Layout.....</b>	<b>pg. 34</b>
<b>Straightener SA3 - SB4 .....</b>	<b>pg. 35-36</b>
<b>Rapid Roll .....</b>	<b>pg. 37-38</b>

UNIT	"A"	"B"	"C"	"D"
SBX-4	28.0	20.0	46.5	40.5
SBX-8	28.0	26.0	46.5	40.5
SBX-12	28.0	26.0	46.5	40.5

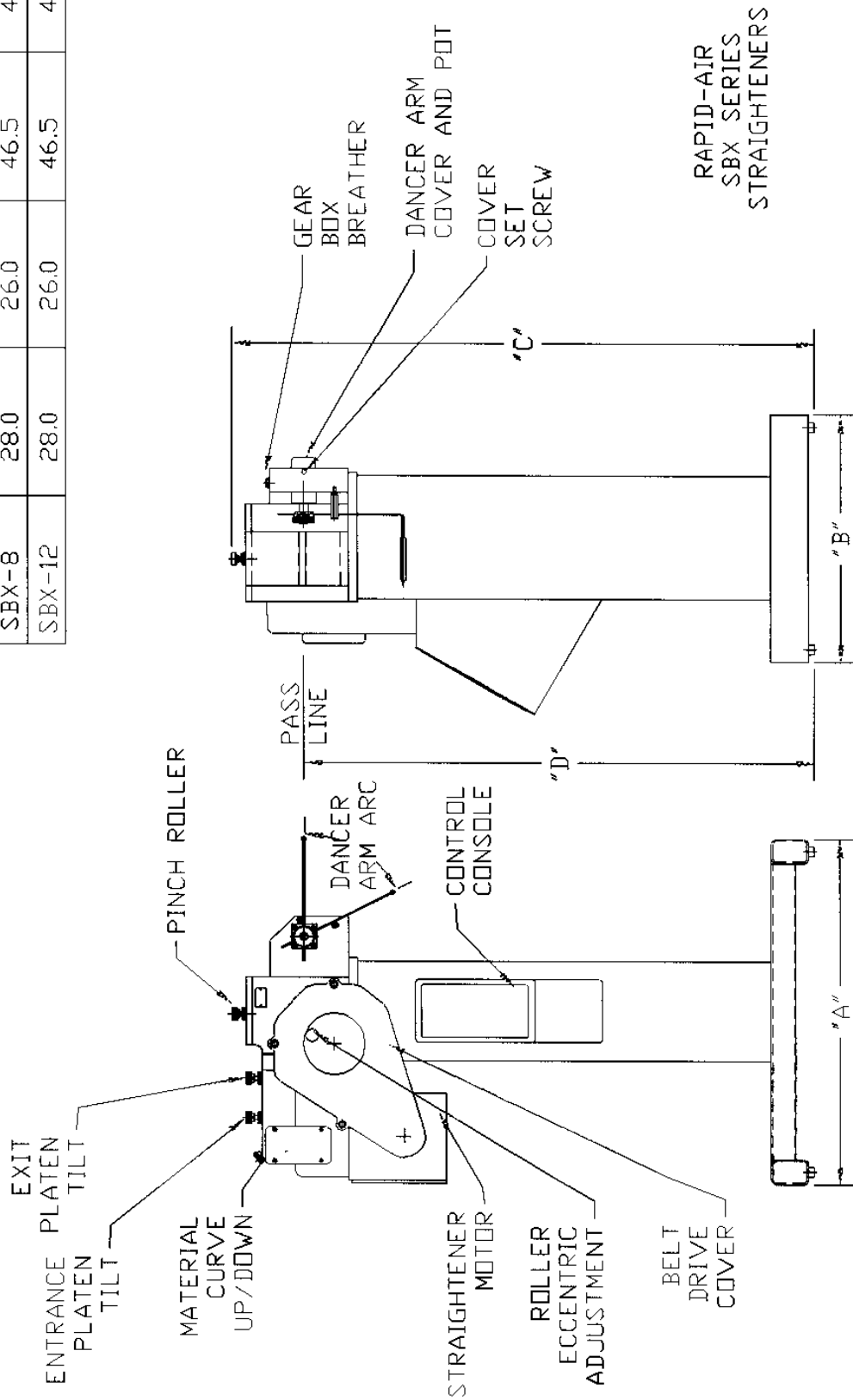

## SCX & SD Series

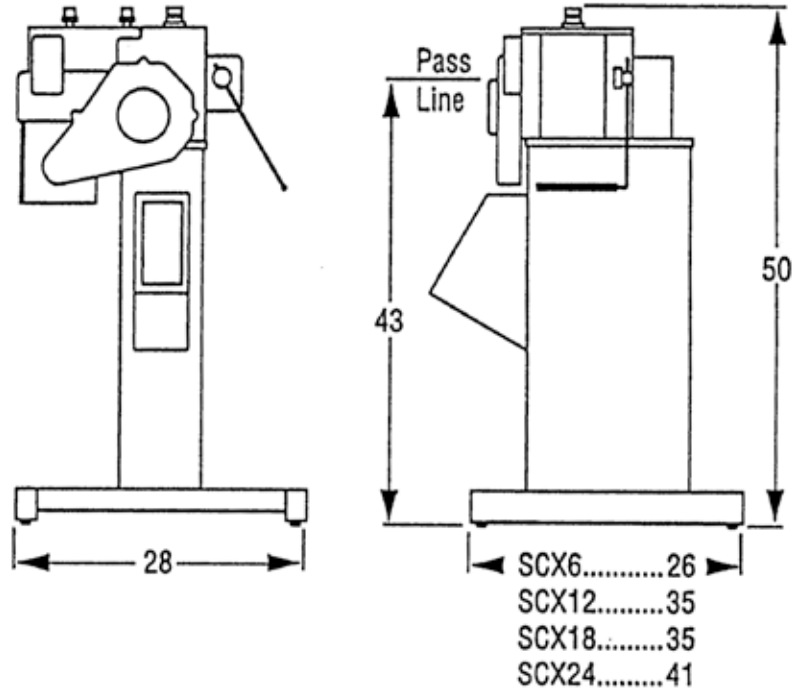

## SCX & SD Series with Inclined Head

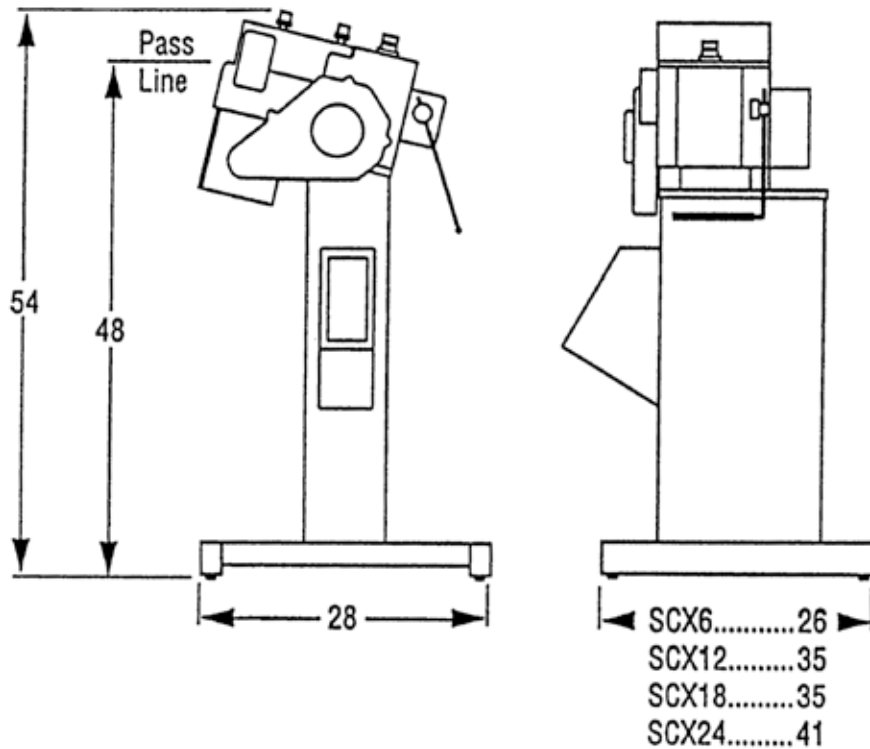

## Adjustable Platen Stock Straighteners vs. Straighteners with Traditional Vertical Roll Adjustment

**CONCEPT:** The concept behind a movable platen containing the upper bank of rolls for straighteners can be somewhat difficult to grasp, but once the principles are understood the superiority of this system becomes obvious. To explain the differences between the adjustable platen system and one that uses traditional single-point vertical roll adjustment, we are describing both types of systems here.

**VERTICALLY ADJUSTABLE UPPER ROLLS:** For centuries the bending of materials has been done by variations of a three-roll arrangement as illustrated in **Figure 1**.

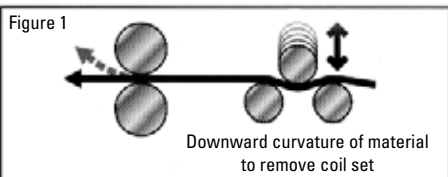

Bending occurs when one roll is forced into the space between the other two rolls for downward curvature of the material to remove coil set. Pressroom straighteners add multiple three-roll combinations in order to level the material in small increments at each stage. This method can provide acceptable results for some materials, but is limited because correction of material curvature is effective in only one direction as illustrated in **Figure 2**.

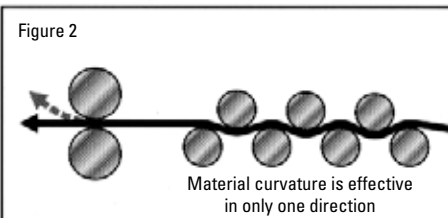

If the straightener is made to correct a clockwise curvature, it is often impossible to correct a counterclockwise curvature. The only available adjustment is the variation of the degree of bend at each station. This is true even for straighteners that have banked upper rolls that pivot for two-point adjustment.

**SIX-WAY UPPER ROLL ADJUSTMENT:** After manufacturing straighteners with vertically adjustable rolls for many years, Rapid-Air developed and patented the adjustable platen type straightener as illustrated in **Figure 3**.

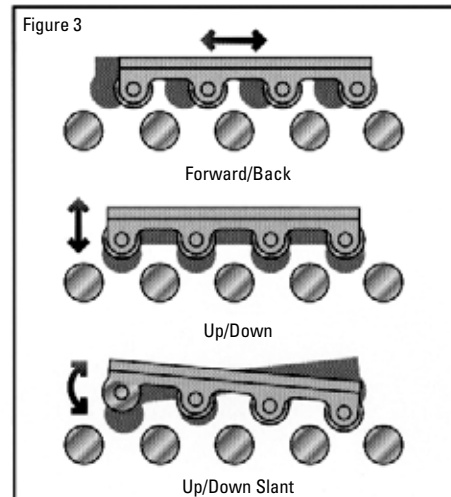

This design mounts the upper rolls in a platen which can be adjusted for *degree of bend* as illustrated in **Figure 4** and **Figure 5**

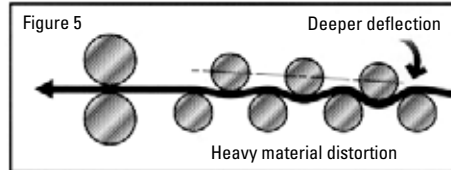
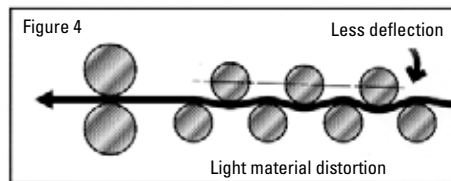

and for *curvature direction* as shown in **Figure 6** and **Figure 7**.

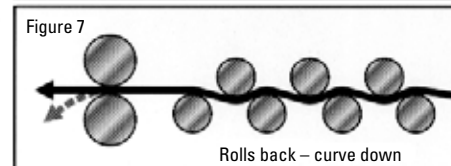
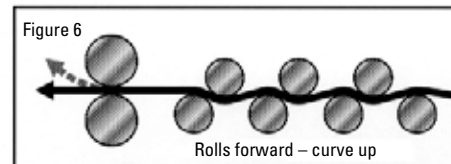

To more easily explain the concept, **Figure 8** shows a three-roll combination with the upper roll forward and **Figure 9** shows a three-roll combination with the upper roll to the rear.

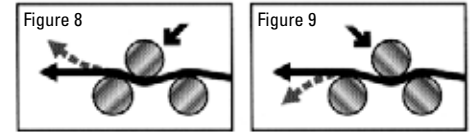

Notice that the sharpest bend occurs where two rolls are in close proximity. When the upper roll is forward, the curvature will be up and when the forward roll is adjusted to the rear, the bend will be down. The degree of bend can be adjusted by a combination of vertical and horizontal adjustments.

**ADVANTAGES:** The high degree of flexibility afforded by the adjustable platen design provides a predictable straightening method for a wide variety of materials and takes a lot of the “Black Magic” out of pressroom straightener setup. The reduction in the flexing and distortion of the strip of material and the reduction of the straightening power required allows effectiveness with heavy materials. Additionally, the ability to place rolls in a proper close proximity allows effective straightening with very thin materials.

**ROLL DIAMETER:** The smaller the roll diameter in a straightener the better it is able to remove distortions in the strip of material, but this factor is compromised by the requirement of larger rolls in wider models of straighteners in order to prevent deflection of the rolls themselves. Rapid-Air straighteners are designed to optimize all factors (including number of rolls, diameter and position) within the published material capacities and specifications for each model.

**SWING-OPEN TOP:** Rapid-Air developed and introduced the swing-open top for straighteners in order to facilitate the cleaning of rolls and the threading of a new strip of material through the straightening rolls. For convenience and safety, each top is counterbalanced and held in the open position until it is clamped for operation. Roll adjustment settings are maintained when the top is closed and locked.

**AVAILABILITY:** All models of Rapid-Air straighteners are presently available with the adjustable platen design with an expanded range of models being introduced in the coming months.



**SA**  
Series

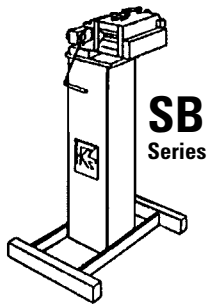

**SB**  
Series

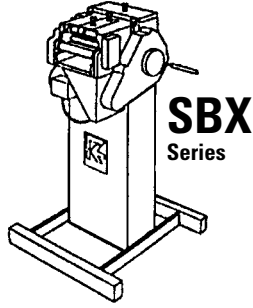

**SBX**  
Series

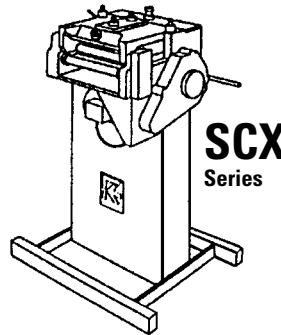

**SCX**  
Series

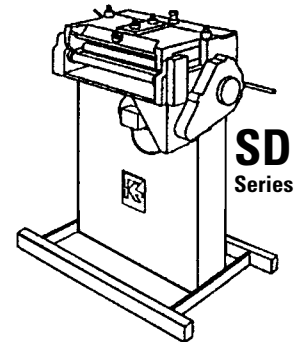

**SD**  
Series

## SPECIFICATIONS

Model	Max Material Width	Effective Straightening Range	Max Speed per min	Speed	Straightening Rolls No., Dia.	Pinch Rolls (2) Dia.	Drive Motor (HP)	Input Power (vac/ph)
SA3	3" (76mm)	.002" - .030" (.051-.76mm)	700" (1778cm)	Standard	11, 3/8 (9.53mm)	1-1/2 (38.1mm)	1/4	115/1
SA3M	3" (76mm)	.002" - .030" (.051-.76mm)	1,400" (3556cm)	Medium	11, 3/8 (9.53mm)	1-1/2 (38.1mm)	1/2	115/1
SB4	4" (102mm)	.003" - .050" (.076-1.27mm)	700" (1778cm)	Standard	11, 5/8 (15.86mm)	1-1/2 (38.1mm)	1/2	115/1
SB4M	4" (102mm)	.003" - .050" (.076-1.27mm)	1,400" (3556cm)	Medium	11, 5/8 (15.86mm)	1-1/2 (38.1mm)	1/2	115/1
SBX4	4" (102mm)	.004" - .080" (.10-2.03mm)	825" (2100cm)	Standard	9, 7/8 (22.23mm)	1-3/4 (44.45mm)	3/4	115/1
SBX8	8" (203mm)	.004" - .070" (.10-1.78mm)	825" (2100cm)	Standard	9, 7/8 (22.23mm)	1-3/4 (44.45mm)	3/4	115/1
SBX12	12" (305mm)	.004" - .060" (.10-1.52mm)	825" (2100cm)	Standard	9, 7/8 (22.23mm)	1-3/4 (44.45mm)	3/4	115/1
SBX4M	4" (102mm)	.004" - .080" (.10-2.03mm)	1,650" (4200cm)	Medium	9, 7/8 (22.23mm)	1-3/4 (44.45mm)	1	115/1
SBX8M	8" (203mm)	.004" - .070" (.10-1.78mm)	1,650" (4200cm)	Medium	9, 7/8 (22.23mm)	1-3/4 (44.45mm)	1	115/1
SBX12M	12" (305mm)	.004" - .060" (.10-1.52mm)	1,650" (4200cm)	Medium	9, 7/8 (22.23mm)	1-3/4 (44.45mm)	1	115/1
SCX6	6" (152mm)	.006" - .100" (.15-2.54mm)	825" (2100cm)	Standard	9, 1-3/8 (34.93mm)	1-3/4 (44.45mm)	1	115/1
SCX12	12" (305mm)	.006" - .090" (.15-2.29mm)	825" (2100cm)	Standard	9, 1-3/8 (34.93mm)	1-3/4 (44.45mm)	1	115/1
SCX18	18" (457mm)	.006" - .080" (.15-2.03mm)	825" (2100cm)	Standard	9, 1-3/8 (34.93mm)	1-3/4 (44.45mm)	1	115/1
SCX24	24" (610mm)	.006" - .065" (.15-1.65mm)	825" (2100cm)	Standard	9, 1-3/8 (34.93mm)	1-3/4 (44.45mm)	1	115/1
SCX6M	6" (152mm)	.006" - .100" (.15-2.54mm)	1,650" (4200cm)	Medium	9, 1-3/8 (34.93mm)	1-3/4 (44.45mm)	2	230/1
SCX12M	12" (305mm)	.006" - .090" (.15-2.29mm)	1,650" (4200cm)	Medium	9, 1-3/8 (34.93mm)	1-3/4 (44.45mm)	2	230/1
SCX18M	18" (457mm)	.006" - .080" (.15-2.03mm)	1,650" (4200cm)	Medium	9, 1-3/8 (34.93mm)	1-3/4 (44.45mm)	2	230/1
SCX24M	24" (610mm)	.006" - .065" (.15-1.65mm)	1,650" (4200cm)	Medium	9, 1-3/8 (34.93mm)	1-3/4 (44.45mm)	2	230/1
SCX6H	6" (152mm)	.006" - .080" (.15-2.03mm)	4,100" (10400cm)	High	9, 1-3/8 (34.93mm)	1-3/4 (44.45mm)	3	230/1
SCX12H	12" (305mm)	.006" - .070" (.15-1.78mm)	4,100" (10400cm)	High	9, 1-3/8 (34.93mm)	1-3/4 (44.45mm)	3	230/1
SCX18H	18" (457mm)	.006" - .060" (.15-1.52mm)	4,100" (10400cm)	High	9, 1-3/8 (34.93mm)	1-3/4 (44.45mm)	3	230/1
SCX24H	24" (610mm)	.006" - .055" (.15-1.40mm)	4,100" (10400cm)	High	9, 1-3/8 (34.93mm)	1-3/4 (44.45mm)	3	230/1
SD6	6" (152mm)	.006" - .125" (.15-3.18mm)	825" (2100cm)	Standard	9, 1-3/8 (34.93mm)	1-3/4 (44.45mm)	2	230/1
SD12	12" (305mm)	.006" - .125" (.15-3.18mm)	825" (2100cm)	Standard	9, 1-3/8 (34.93mm)	1-3/4 (44.45mm)	2	230/1
SD18	18" (457mm)	.006" - .100" (.15-2.54mm)	825" (2100cm)	Standard	9, 1-3/8 (34.93mm)	1-3/4 (44.45mm)	2	230/1
SD24	24" (610mm)	.006" - .090" (.15-2.29mm)	825" (2100cm)	Standard	9, 1-3/8 (34.93mm)	1-3/4 (44.45mm)	2	230/1
A right-to-left material flow direction is standard for above models — left-to-right optional at no additional cost.								
SC4	4" (102mm)	.015" - .085" (.38-2.13mm)	825" (2100cm)	Standard	9, 1-1/4 (31.75mm)	1-1/4 (31.75mm)	1	115/1



Model SC4

Model SC4 Straightener with individually adjustable upper rolls. This 4" x .085" capacity straightener with its counterbalanced swing-open top is a Rapid-air original and continues to be available due to customer acceptance and demand. Dial-type indicators for roll settings are optional.

**A NOTE ON ROLL DIAMETER AND QUANTITY:**  
The smaller the roll diameter in a straightener the better it is able to remove distortions in the strip of material. Rapid-Air straighteners are designed to optimize all factors (including number of rolls, diameter and position) within the published material capacities and specifications for each model.

# INSTALLATION

---

## Operating Instructions For Straighteners / Rapid Roll

Align the Rapid Roll with the feed allowing sufficient space for free stock for the feed. The loop control arm roller rests on the stock between the Rapid Roll and the press. The Rapid Roll should be bolted to the floor, especially when used to pull stock from a non-powered reel.

The pinch rolls must be parallel in the lateral (horizontal plane to insure that there will be equal pinch force along the full width of the stock). An upper pinch roll adjustable eccentric trunion is slotted with a locking screw in

its center. Adjust parallelism of the rolls by loosening the center screw and rotating the trunion through 180 degrees. A wide blade screwdriver and allen wrench may be used. Use a feeler gauge to check for equal spacing on either side of the pinch rolls.

Perform a visual check by lifting the cover and placing a white piece of paper in front of the pinch rolls to reflect light through the space between. Tighten the pinch roll knob so the rolls just touch. Observe the slit of reflected light between the rolls and make

any final adjustment. Tighten the trunion lock screw. Raise the pinch roll to allow clearance for the next setup procedure.

The main control unit is located behind the side access cover. On pages 9 & 10 is an illustration of the layout of the control panel. This diagram lists all the components and the approximate location of each that could be used for troubleshooting the machine if a problem should occur. The reel is shipped with - 120 vac (1 phase) input. Visually check all electrics before starting the reel.

# START UP PROCEDURE

---

Prior to applying power to the straightener, all the controls on the machine should be reviewed. A brief summary is listed below.

## Main Console And Controller

The main control console with controls is mounted on the cabinet of the straightener. Located on the face of the console are five switches, one potentiometer, one push-button and one or two circuit breaker reset switches, which are explained below.

### 1. ON/OFF SWITCH

This illuminated switch is the main power switch for the controller. On the 120 VAC straighteners, it will be a toggle switch and on the 230 VAC version it will be a mushroom push-button. It must be "ON" for the straightener to function.

### 2. RESET BUTTONS (circuit breaker)

#### 120 VAC.

**a. 15 amp** – This is the main circuit breaker for the straightener.

**b. 3 amp** – This is the main circuit breaker for the "D-SUB" (25 pin) connector. Any shorting or overloads would trip this breaker.

#### 240 VAC.

**a. 3 amp** – This is the main circuit breaker for the "D-SUB" connector. Any shorting or overloads would trip this breaker.

### 3. RUN/STOP/JOG SELECTOR SWITCH

a. If "RUN" was selected and the dancer control arm was raised, the straightener rolls would rotate. If "STOP" was selected then none of the functions would work. If "JOG" was selected then the jog button has to be depressed to have the straightener rolls rotate.

### 4. JOG BUTTON

Used for intermittent movement of the straightener rolls and mainly for setup. The jog speed can be adjusted by rotating the R3 potentiometer on the 69100079 board in the control sub panel.

### 5. % SPEED POTENTIOMETER

The % speed potentiometer adjusts the maximum speed that the straightener rolls can rotate regardless of the dancer arm height. It should be set to maintain a constant material feed rate through the straightener.

### 6. DANCER ARM LOOP HEIGHT AND RANGE ADJUSTMENT

**a. Loop Range** – The loop range switch adjusts the amount of travel that the dancer arm will move to provide the full range of speed on the straightener. It has three positions with a "0" as the least travel from slowest to fastest speed and a "2" has the most movement between slowest to fastest speed.

**b. Loop Height** – The loop height switch is used for setting the start position of the control arm. It has three positions with the "0" setting having the start position at the dancer arm rest position and the "2" having the start position somewhat higher than the dancer arm rest position. This setting will determine the dancer arm angle that the reel will start turning. This function is used to accommodate different thickness of material which

would have a different bend radius thus requiring the dancer arm to be at a height somewhat above the home position when at rest.

### 7. LOOP ARM / EXTERNAL SWITCH

This switch is used to select whether the material loop is controlled by the dancer arm or an external loop control. If LOOP ARM is selected then the control will monitor the dancer arm movement. If EXTERNAL is selected then the control will monitor whatever is plugged into the "D-SUB" (25 pin) connector.

### 8. REMOTE INTERFACE PORT "D" CONNECTOR

This 25 pin connector, located on the lower portion of the console is used to communicate with external loop equipment. The RSB, RTB, & RTA will plug into the port and can immediately be implemented.

**CAUTION:** Never plug any type of computer or non Rapid-Air equipment into this plug or severe damage could result. Always consult the factory when installing different external controls for advice on compatibility and wiring information.

### 9. PANEL MOUNTED ELECTRICAL COMPONENT DESCRIPTION

69100034 board – proportional control board

69100076 board – component interface board

69100014 board – (RAMM) D.C. motor control board [120 VAC, 1 PH]

69100038 board – (RAMM) D.C. motor control board [240 VAC, 1 PH]

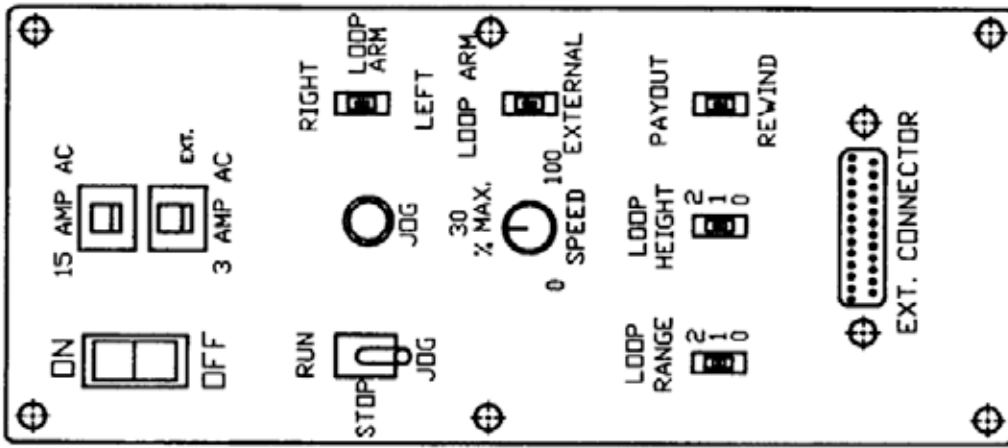

FRONT VIEW

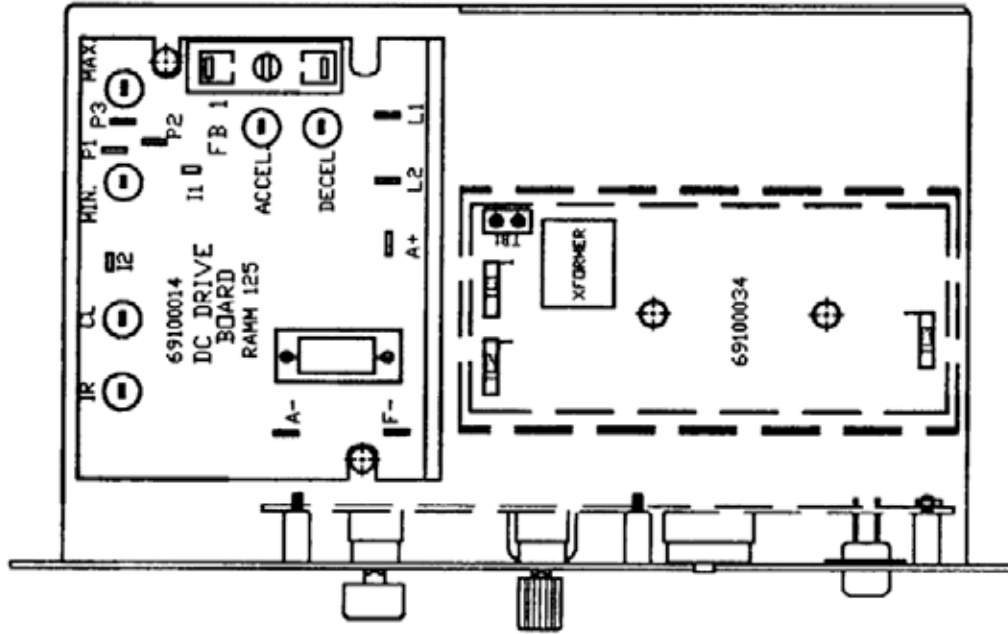

SIDE VIEW

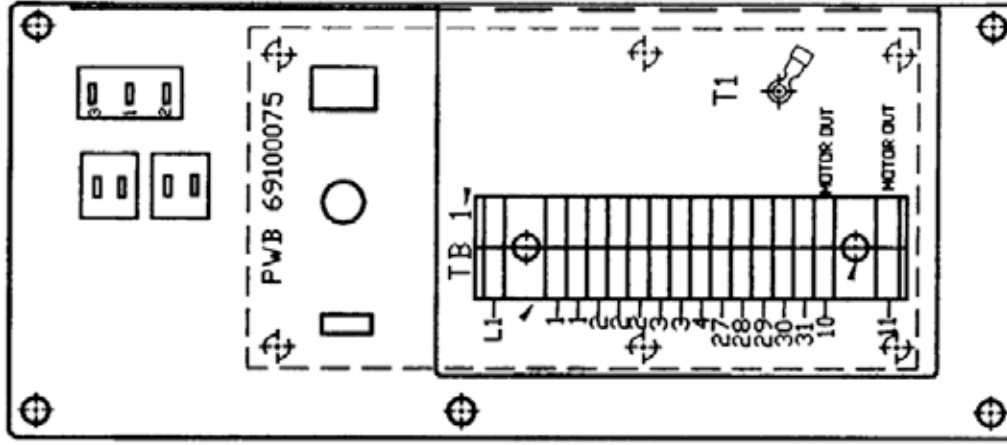

BACK VIEW

# 1 HP AND LOWER CONTROL

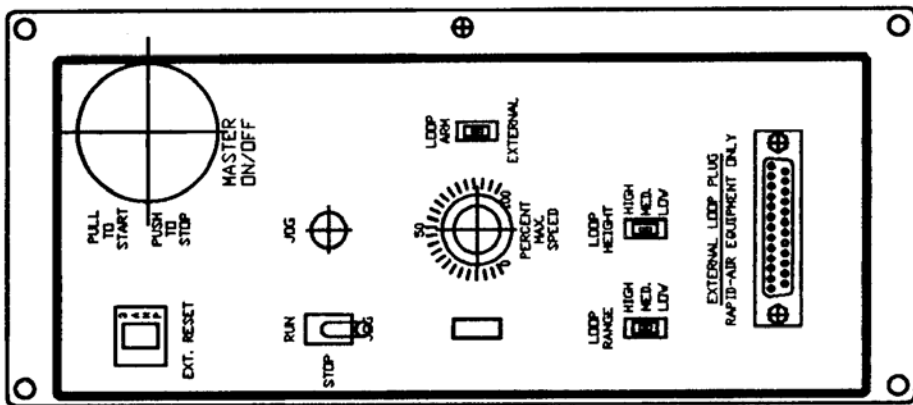
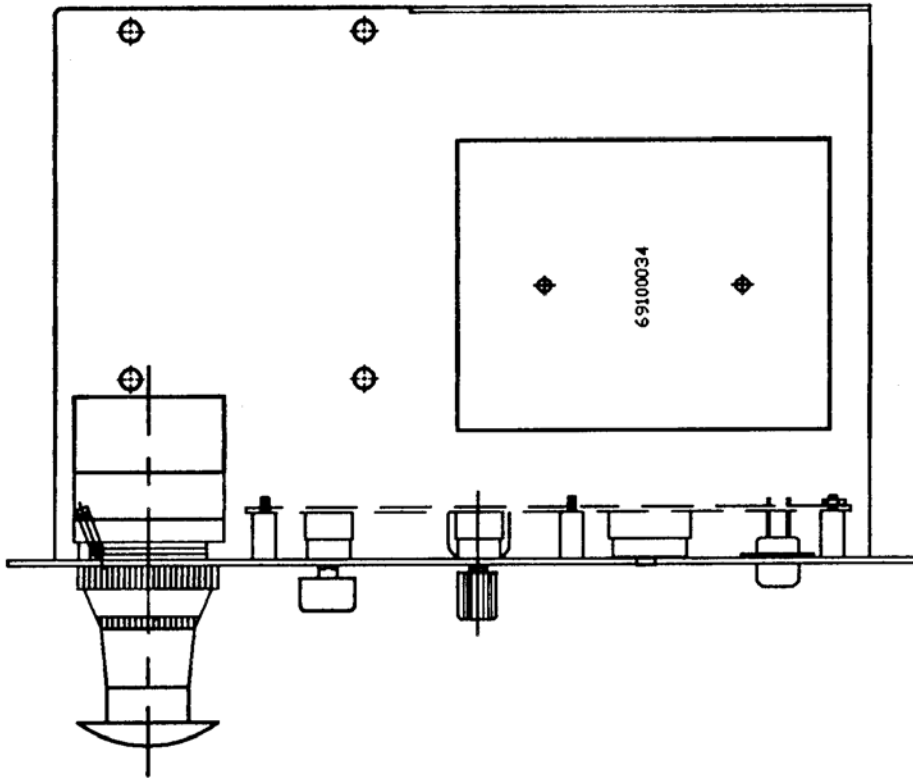
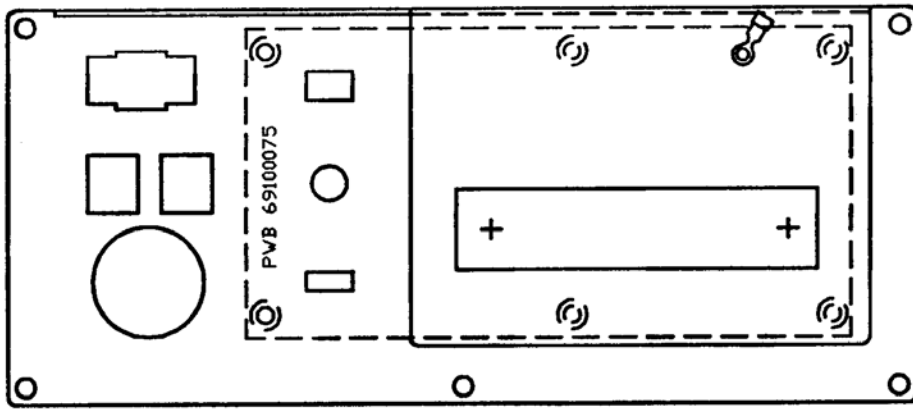

# 2 & 3 HP CONTROL

# DANCER ARM LOOP

## Dancer Arm Loop Height Adjustment

Three different loop sensing arm operating positions are selected manually during set-up. By selecting the higher number, the zero point of the dancer arm is raised from its rest position to the angle shown (as indicated 0-2). The dancer arm will move from rest position to the angle selected before the straightener rolls begin to rotate.

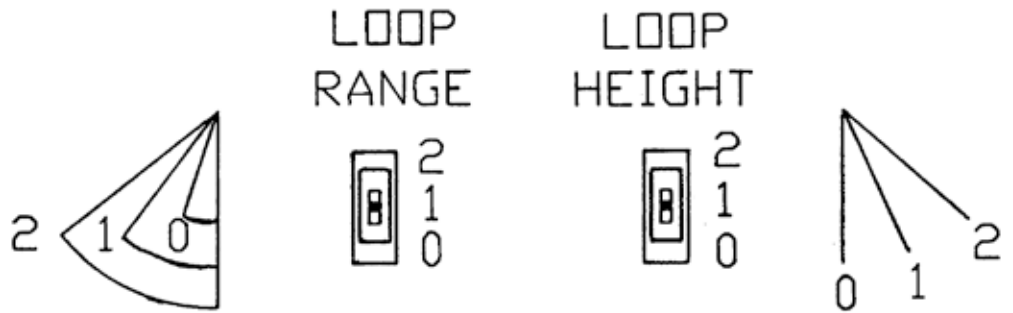

## Dancer Arm Loop Range Function

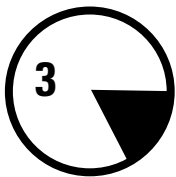

30 degree — Loop sensing arm travels through a full 30 degree arc to vary rotation speed from slow to full speed as controlled by % speed pot.

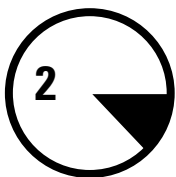

20 degree — Loop sensing arm travel through a 20 degree arc to vary speed from slow to full speed as controlled by % speed pot.

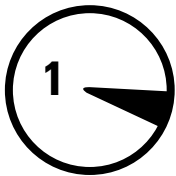

10 degree — Loop sensing arm travels through a 10 degree arc to vary rotation speed from slow to full speed as controlled by % speed pot.

# STANDARD STRAIGHTENER COMPONENTS

---

## Curve Up/Down Adjustment

Some applications have dies that cannot accept anything but flat stock and other dies run better with the material curving up or down to miss the built in edge required in the die. Before this feature was added, operators would under straighten or over straighten the material to suit their needs but in doing so would severely change the material entering the die. This not only caused feeding problems but part quality problems. With this feature, curve up or down can be accomplished by changing the position of the rolls without stressing the material.

## Entrance Guide Roll Block

All straighteners are shipped with an entrance guide roll. This contains a roller and two adjustable edge guides.

# OPTIONAL STRAIGHTENER COMPONENTS

---

## Entrance Cascade Roll

The entrance cascade roll assembly is used to maintain a support arc for stock entering a feed. The cascade roll has three extra rollers to help the material flow better.

## Exit Cascade Roll

The straightener is shipped with the exit side pre-drilled for the cascade roll or guide roll block. The entrance and exit use the same components.

## Angle Bracket

Rapid-Air offers this accessory that mounts between the straightener head and the base. It angles the exit side of the straightener twelve degrees lower than the entrance side. This feature works very well when using the straightener to pull off a non-powered reel.

# OPERATION

---

Once the straightener has been tested and all the functions work, then it should be tested for what it was designed to do and that is to remove coil set.

Retract all of the idler rolls and the exit pinch roll to a position so when the cover is closed the material is not being deformed. Open the cover of the straightener and position the edge guides for maximum width. Cut and place about a four foot length of the material onto the straightener rolls with the exit end of the material extending through the exit pinch rolls and centered from side to side in the straightener. Close the cover and latch it. Adjust the exit pinch roll enough to grip and hold the material. Adjust the edge guides so that they just touch the material.

Adjust the first idler roll knob, this is the one nearest the entrance of the straightener, so that it deforms the material no more than the thickness

of the material. Adjust the second idler roll knob so it is lightly on the roll. Run the material to check that the exit pinch roll is not slipping on the material, readjust if necessary. This piece will still have coil set in the first two feet of the material as it was not run through the complete straightening cycle. At this time, this piece could be rerun and checked for straightness or a new piece could be cut and run and then be checked.

A good check is to guide the exiting material, keeping it parallel to the rolls, until the run is complete and then hold one end of the material in the air while peering down the length of the material. If the material still has "coil set" then readjust roll pressure on the last roll, towards the exit end but before the pinch roll, until the material is straight. Run one or more short length setups while making final adjustments. Once the proper setting has been determined, the quick release top maintains the adjustment during loading.

Thread the material from the reel through the straightener, under the dancer arm, and into the pulling device leaving ample loop between the straightener and the pulling device. If the material thickness is such that when exiting the straightener, it will not let the dancer arm down to the rest position, then either lengthen the dancer arm or adjust the loop height until the straightener stops feeding.

Set the % speed potentiometer to 50% for a starting position and start the pulling device to have the material feeding. If the straightener gets finished and stops before material is needed again then the straightener is set to feed too fast, slow it down by adjusting the % speed potentiometer. The ideal straightening is to have the straightener slightly exceed the feed rate required. This minimizes the starting and stopping and resultant stock deformation.

# MAINTENANCE

---

## Lubrication

### Gear transmission

The reservoir oil capacity is about 4 oz. The reservoir oil should be changed every 2000 hours and should be filled to the oil level site gauge. Use MOBILE 600W cylinder oil or equivalent. This is a non-synthetic oil.

### Rolls

Although the rolls should be cleaned periodically they never have to be greased as all the rolls have permanently lubricated bearings.

### Drive belt

At the oil change interval, check for belt tension and wear.

# TROUBLESHOOTING GUIDE

---

## MAIN SWITCH ON BUT NOT LIT

1. CB tripped.
  - a. Reset CB.
2. Unit not plugged into main power.
  - a. Plug into main power source.
3. No power in incoming line.
  - a. Check outlet.
  - b. Check power cord.
4. Loose wiring.
  - a. Check terminals and connections.

## MOTOR CREEPS IN STOP POSITION

1. R1 & R3 pot on 69100034 board not correctly adjusted.
  - a. Readjust pots so rollers stop.  
Call factory.

## UNIT TURNS BUT WON'T JOG

1. Selector switch not in jog position.
  - a. Select jog.
2. Jog pot on 69100076 board not adjusted correctly.
  - a. Adjust pot. Call factory
3. Maximum speed pot on Ramm board set too low.
  - a. Adjust pot.

## UNIT ON BUT MOTOR WON'T RUN. (ARMATURE VOLTAGE PRESENT – ON RAMM BOARD)

1. Check motor wiring and fuse.
  - a. Replace motor cord and correct motor wiring. Call factory.
2. Check motor.
  - a. Worn brushes or motor defective. Call factory.

## UNIT ON BUT MOTOR WON'T RUN. (NO ARMATURE VOLTAGE ON RAMM BOARD)

1. Selector switch not in run position.

- a. Turn selector switch to run position.
2. If running with a dancer arm control.
  - a. Check that the external/loop switch is in the loop arm position.
3. If running with external control.
  - a. Check that the external/loop arm switch is in the external position.
4. Height switch setting too high.
  - a. Set height setting to "0".
5. Percent speed pot set too low.
  - a. Adjust percent speed pot to 100%.
6. Fuses blown.
  - a. Check fuses & circuit breaker.
7. No AC voltage at DC drive board.
  - a. Check wiring.
8. Check Signal voltage between P2 to I2 on DC drive.  
0-6 VDC—Ramm  
0-9 VDC—Regen Drive while moving dancer arm.
  - a. If there is a signal, check continuity between I1 & I2.
  - b. If no continuity, replace D.C. drive or call factory.
9. Check line voltage input of 69100034 board, 120 VAC, TB-1.
  - a. Check wiring. Call factory.
10. Check pico fuse 69100034 board (f1).
  - a. Replace fuse, 1 amp pico fuse — call factory.
11. Check for 0-12 VDC between pin #1 (=V) and pin #2 (GND) of panduit connector TC3 on board #69100034.
  - a. If no voltage present, call factory.

12. Check for DC voltage between pin #6 (VO) and pin #2 (GND) of panduit connector TC3, on board 69100034, while moving the dancer arm from minimum to maximum position.
  - a. If voltage is present, turn power off and check the ribbon cable connections between panduit connector #TC3 of 69100034 board and panduit connector #TB-4 of 69100076 board. This should be a continuity check for tight connections. Call factory for assistance.
  - b. If voltage is not present move on to step 13.
13. Check voltage between pin #5 of TB-6 & pin #3 of TB-5 on 69100076 board while moving the dancer arm from minimum to maximum position.
  - a. If voltage varies 2.5-4 volt from minimum to maximum position, the dancer arm pot is OK, but the 69100076 board could be defective. Call factory.
  - b. If voltage does not vary when moving the dancer arm from minimum to maximum position — call the factory for assistance.

# 69100034 TAUT STOCK OUTPUT

The 69100034—Proportional control board has a taut stock output. The output must be wired to a solid state relay as the max current draw is 20 MA. The solid state relay's contact can then be incorporated into the electrical control circuitry.

The output can be wired so that the relay is either on or off with the dancer arm down. When the dancer arm reaches the set point for taut stock, the relay switches state.

The taut stock height set point is set by raising the dancer arm to a position that the material is taut and then adjusting pot R7 so the output changes state. Lower and raise the dancer arm a few times to check that the set point repeats and then the set point is finished.

The potentiometer that is located just below the taut stock terminal strip is used for presetting the max voltage output requirement for a particular

drive. A RAMM DC drive needs 6 VDC for max motor speed so turn the pot fully counter clockwise. A minarik drive board needs 10 VDC for max motor speed so turn the pot fully clockwise.

The following is a brief wiring diagram for the taut stock.

3	GRD
2	10 VDC out with dancer arm down
1	0 VDC out with dancer arm down

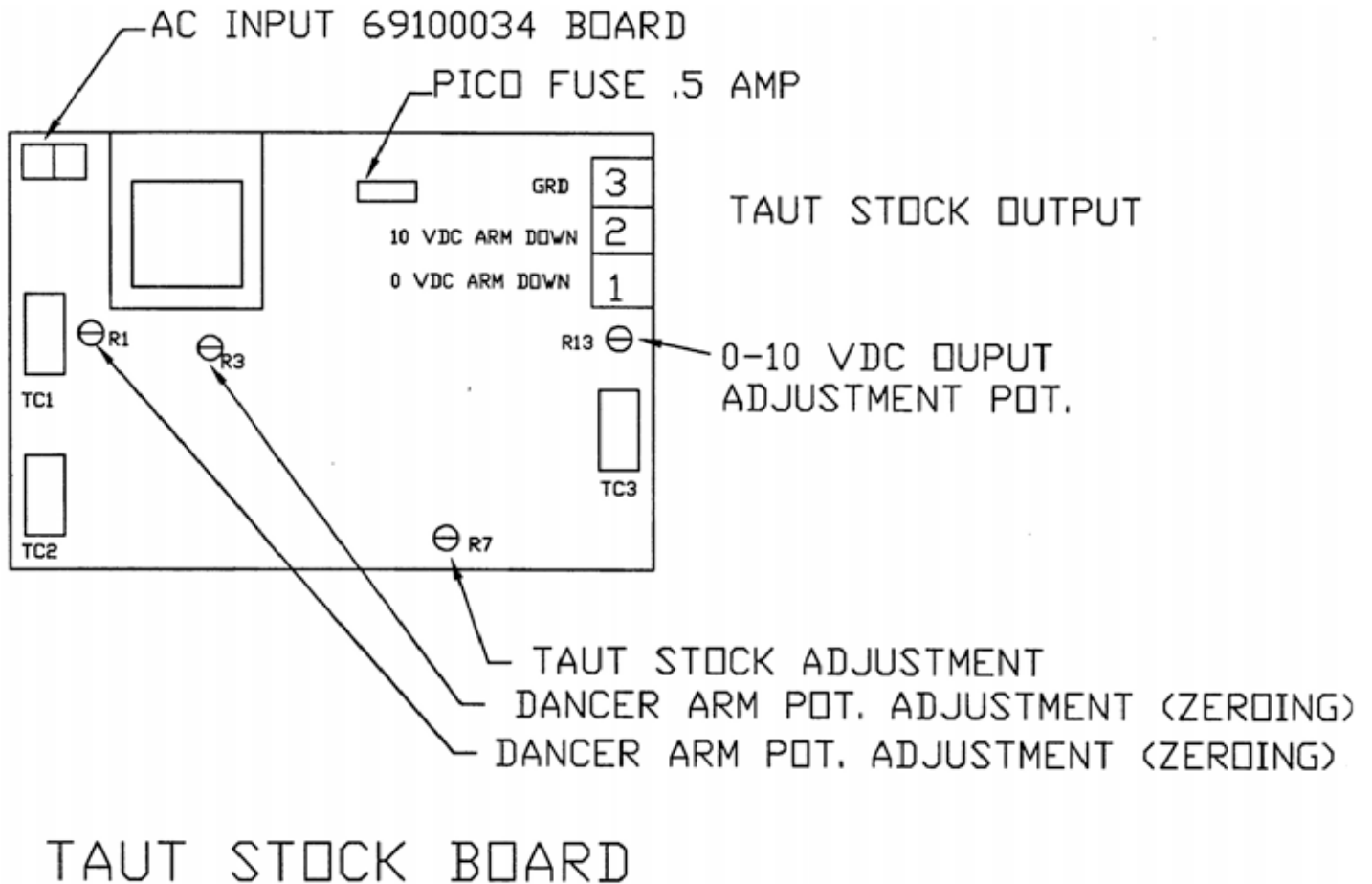

# SAFETY WARNING – PLEASE READ CAREFULLY

## RAMM Solid State DC Motor Speed Control

This product should be installed and serviced by a qualified technician, electrician or electrical maintenance personnel familiar with its operation and the hazards involved. Proper installation (see instruction information which accompanies product), which includes wiring, mounting in proper enclosure, fusing or other overcurrent protection and grounding, can reduce the chance of electrical shocks, fires or explosion in this product or products used with this product, such as electric motors, switches, coils solenoids and/or relays. Eye protection must be worn when working with control under power. This product is constructed of materials (plastics, metals, carbon, silicon, etc.) which may be a potential hazard. Individual material safety data sheets (MSDS) are available upon request. Proper shielding, grounding and filtering of

this product can reduce the emission of radio frequency interference (RFI) which may adversely affect sensitive electronic equipment. If information is required on this product, contact our factory. It is the responsibility of the ultimate user of this product to read and comply with this safety warning. (SW effective 1/89)

**\*\*\*IMPORTANT\*\*\*  
YOU MUST READ THESE  
INSTRUCTIONS BEFORE  
OPERATING CONTROL**

1. Be sure AC line voltage corresponds to control voltage.

2. Install the correct Plug-In Horsepower Resistor according to armature voltage and motor horsepower.
3. Recheck connections: AC line to L1 and L2; armature to A+ and A- and field (Shunt motors only to F+ and F-.) (**Note:** If motor runs in improper direction, interchange armature leads.)
4. Install proper AC line fuse and armature fuse as required.
5. Nominal trimpot settings are as follows (expressed in % of full CW rotation):

**TABLE 1: NOMINAL TRIMPOT SETTINGS**

MIN (minimum speed):	15%	CL (current limit/torque):	65%
MAX (maximum speed):	65%	ACCEL (acceleration start):	20%
IR (IR compensation):	25%	DECEL (deceleration stop):	20%

## Plug-In Horsepower Resistor

A Plug-In Horsepower Resistor must be installed to match the RAMM to the motor horsepower and voltage. See table 2 for the correct value. Plug-In Horsepower Resistors are stocked by your distributor.

**TABLE 2: PLUG-IN HORSEPOWER RESISTOR CHART\***

MOTOR HORSEPOWER RANGE **		Plug-in Horsepower Resistor Resistance Value (ohms)	Rapid-Air Part Number
Armature Voltage 90-130 VDC	Armature Voltage 180 VDC		
1/4	1/2	.05	69100529
1/2	1	.025	69100530
3/4	1-1/2	.015	69100534
1***	2***	.01	69100531

\* Motor horsepower and armature voltage must be specified when ordering so that proper resistor will be supplied.

\*\* For overlapping motor horsepower range use lower value Plug-In Horsepower Resistor.

\*\*\* Auxiliary heat sink must be used to achieve HP rating.

# INTRODUCTION

## RAMM Full Wave Solid State DC Motor Speed Control

The **RAMM** Full Wave Solid State DC Motor Speed Control represents the latest state of the art design achievable through modern technology.

### FEATURES INCLUDE:

#### Integrated Circuitry

Used to control and amplify command and reference levels with both closed and open loop feedback to provide superior motor regulation. (Speed changes due to load, line voltage, or temperature variations are held to minimum levels).

#### High Quality Components

Selected and tested for proven dependability.

#### Transient Protection

Used to prevent failure of the power bridge circuit caused by voltage spikes on the AC line.

#### High Reliability

When used in accordance with instructions in this manual, the RAMM will provide years of trouble free operation.

### A. INITIAL SETUP AND WIRING

#### General Instructions

1. Install proper size Plug-In Horsepower Resistor (see table 2).
2. The RAMM can be connected to a standard 120V or 240V 50/60 Hz AC line (be sure the AC input voltage corresponds to the control voltage rating and the motor rating). (e.g. 90-130 VDC motor on 120VAC and 180 VDC motor on 240 VAC).

3. Follow the recommended supply wire sizes as per table 3.
4. Follow the NEC and other electrical codes that apply.

**CAUTION:** SEPARATE BRANCH PROTECTION MUST BE PROVIDED ON 240V CIRCUITS.

5. Connect control in accordance to connection diagram.

**TABLE 3: MINIMUM SUPPLY WIRE SIZE REQUIREMENTS**

Max. Motor Amps (DC Amps)	Max. Motor HP 90V	Max. Motor HP 180V	Max. Motor Run	Minimum Wire Size (AWG) Cu only Max. Motor Run
6.0	1/2	1	16	14
12.0	1	2	14	12*
16.0	1-1/2	3	12	12

\* Maximum recommended wire size.

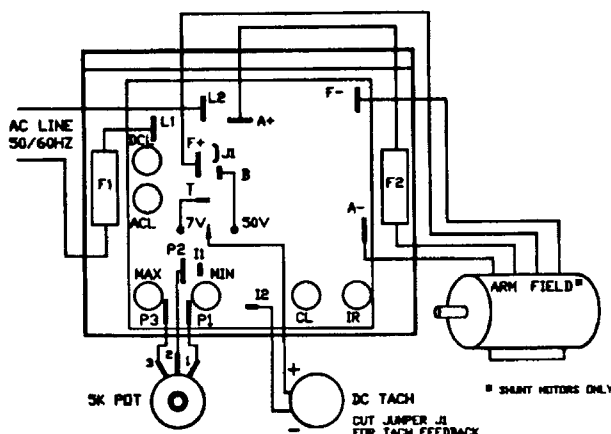

**FIGURE 1: BASIC RAMM CONNECTION DIAGRAM**

**CAUTION:** DO NOT BUNDLE POTENTIOMETER CONNECTIONS (P1, P2, P3) AND INHIBIT CONNECTIONS (I1, I2) WITH AC LINE OR MOTOR WIRES.

### B. VOLTAGE FOLLOWING

All models can be controlled with an isolated analog reference voltage (0-6VDC) in lieu of the main speed potentiometer. The voltage is connected to P2 (+) and F-. The control output voltage will linearly follow the

input voltage. The source impedance of the input should be 10K ohms or less. The Min trimpot can be used to provide an offset speed. If an offset is not required, adjust the Min to 0+ or 0- speed as desired. The Max trimpot is rendered inoperative in the voltage following mode. Use auxiliary trimpot to limit the control range. If the input signal is not isolated, or is a current signal (4-20 MA), the RAS1240D Signal Isolator must be used. It will allow direct connection to process controllers and microprocessors.

# INTRODUCTION (CONT.)

## CAUTION:

1. The voltage feeding P2 and F– must be isolated from the AC line. Do not ground P2 or F– to set up a zero ground reference.
2. Do not bundle signal wires to P2 and F– with AC line motor connections. If signal wires are over 18", use shielded cables.

## C. FUSING

The RAMM has provision for a built in AC line fuse and armature fuse. The AC line fuse protects the control against catastrophic failure— if the fuse blows, the control is miswired, the motor is shorted or grounded, or the RAMM control is defective. The armature fuse provides overload protection for the motor and control. Choose the proper size armature fuse by multiplying the maximum DC motor amps by 1.7. On domestic 240 Volt AC lines, separate branch circuit protection for each line must be used. All fuses should be normal blow ceramic 3AG or ABC or equivalent.

1. AC Line Fuse is chosen according to the maximum rating of the control:

– 12 AMP fuse for all motors up to 3/4 HP-90V and 1-1/2 HP-180VDC.

– 25 AMP fuse for all motors 1 and 1-1/2 HP-90V and 2 and 3 HP-180VDC.

(Use Buss ABC, Littlefuse 326 ceramic fuse or equivalent.)

2. Armature Fuse can be chosen in accordance with the fuse chart.

**Note:** The armature fuse is calculated based on the approximate full load DC current rating of the motor times a form factor of 1.5. If motor has characteristics not consistent with these approximations, a different fuse value may have to be used. Fuses are available from your distributor.

**TABLE 4: ARMATURE FUSE CHART**

Horsepower 90 VDC Motor	Horsepower 180 VDC Motor	Approx. DC Motor Current (Amps)	Fuse Rating (AC Amps)
1/4	1/2	2.5	4
1/2	1	5.0	8
3/4	1-1/2	7.5	12*
1	2	10.0	15
1-1/2	3	15.0	25*

\* Also used as AC line fuse.

# ADJUSTMENTS AND CONTROL FUNCTIONS

## RAMM Adjustments And Control Functions

**WARNING:** If adjustments are made under power, insulated adjustment tools must be used and eye protection must be worn.

The RAMM has been factory adjusted to provide 0-full speed using the speed control knob. Minimum and Maximum speed trimpots are provided to change the speed from other than 0-full speed. The Acceleration (ACCEL) trimpot is provided to allow for a smooth start over an adjustable time period each time the AC power is applied or the speed pot is rotated. The DECEL trimpot controls the amount of ramp-down when the speed pot is adjusted to a lower speed. The Current Limit (CL, or torque output) adjustment is factory set to approximately 1-1/2 times the motor rating. The IR Compensation (IR) is factory adjusted to provide excellent motor regulation under normal operation.

**NOTE:** In order for the IR comp and CL trimpot settings to be correct, the proper Plug-in Horsepower Resistor must be installed for the particular motor and input voltage being used. Do not attempt to change the settings of the trimpots unless absolutely necessary since they are factory adjusted to near optimum settings.

The following procedure, presented in order of adjustment sequence, should be used when readjusting all trimpot functions.

**FIGURE 2: ACCEL/DECEL Trimpot ADJUSTMENT**

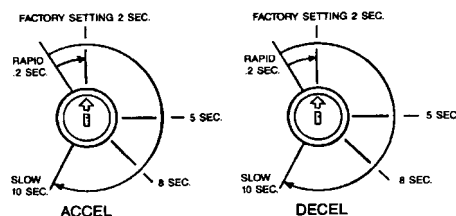

- A. **Acceleration Start.** The ACCEL is factory set at approximately .2 seconds. To readjust to different times, set the knob to the desired position as indicated in Fig 2.
- B. **Deceleration.** The DECEL is factory set to provide a ramp-down time of .2 seconds. To change the ramp-down time, adjust the DECEL trimpot as indicated in Fig 2.
- C. **Minimum Speed Adjustment.** If a higher than zero minimum speed is desired, readjust the minimum speed by turning the speed control knob to zero setting (full CCW position). Then adjust the Min. Speed trimpot to the desired setting.

**NOTE:** The min. speed adjustment will affect the max. speed setting. Therefore, it is necessary to readjust the max. speed after the min. speed is adjusted.

- D. **Maximum Speed Adjustment.** Turn Speed Control Knob to full speed (maximum CW position). Adjust max. speed trimpot to new desired setting.

**NOTE:** Do not attempt to adjust the max. speed above the rated motor RPM since unstable motor operation may occur. For moderate changes in the max. speed, there will be a slight effect on the min. speed setting.

- E. **Current Limit (CL/Torque Adjustment).** CL circuitry is provided to protect the motor and control against overloads. The CL also limits the inrush current to safe level during startup. The CL is factory set to approximately 1.5 times the full load rating of the motor. (CL trimpot is nominally set to approximately 65% of full CW rotation).

To set the CL to factory specifications adjust as follows:

1. Set speed control knob at approximately 30-50% CW rotation. Set CL

- trimpot to full CCW position.
2. Connect a DC ammeter in series with the armature lead.
3. Lock shaft of motor (be sure CL pot is in full CCW position). Apply power and rotate CL pot CW slowly until DC ammeter reads 1.5 times motor rating (do not exceed 2 times motor rating, Max. CW position.)

**NOTE:** If only an AC ammeter is available, it can be installed in series with the AC line. Follow above instructions; however, set AC amperage at .75 times motor rating.

- F. **IR Compensation Adjustment.** IR compensation is provided to substantially improve load regulation. If the load presented to the motor does not vary substantially, the IR adjustment may be set at a minimum level (approximately 1/4 of full setting). The control is factory adjusted to approximately 3% regulation. If superior performance is desired (less than 1% speed change of base speed from 0 to full load), then the IR comp. Should be adjusted as follows:

**NOTES:** 1. Excessive IR comp. will cause control to become unstable, which causes motor cogging.  
2. For tach feedback applications the IR comp can be set to minimum rotation (full CCW).

1. Set IR comp. trimpot at approximately 25% of CW rotation. Run motor unloaded at approximately 1/3 speed and record RPM.
2. Run motor with maximum load and adjust IR comp. trimpot so that the motor speed under load equals the unloaded speed per step 1.
3. Remove load and recheck unloaded RPM. If unloaded RPM has shifted, repeat procedure for more exact regulation.

The RAMM is now compensated to provide minimal speed change under large variations of applied load.

# **WARRANTY**

---

## **Limited Warranty – RAMM 125, 225, 225D**

For a period of one (1) year from date of original purchase Rapid-Air Corporation will repair or replace without charge devices which our examination proves to be defective in material or workmanship. This warranty is valid if the unit has not been tampered with by unauthorized persons, misused, abused or improperly installed and has been used in accordance with the instructions and/or ratings supplied. The foregoing is in lieu of any other warranty or guarantee expressed or implied, and we are not responsible for any expense (including installation and removal), inconvenience, or consequential damage, including injury to any person, caused by items of our manufacture and/or sale. Some states do not allow certain exclusions or limitations found in this warranty so that they may not apply to you. In any event, Rapid-Air Corporation's total liability, under all circumstances, shall not exceed the full purchase price of this unit.

# Wiring Diagram for STD Speed Straighteners (1-HP)

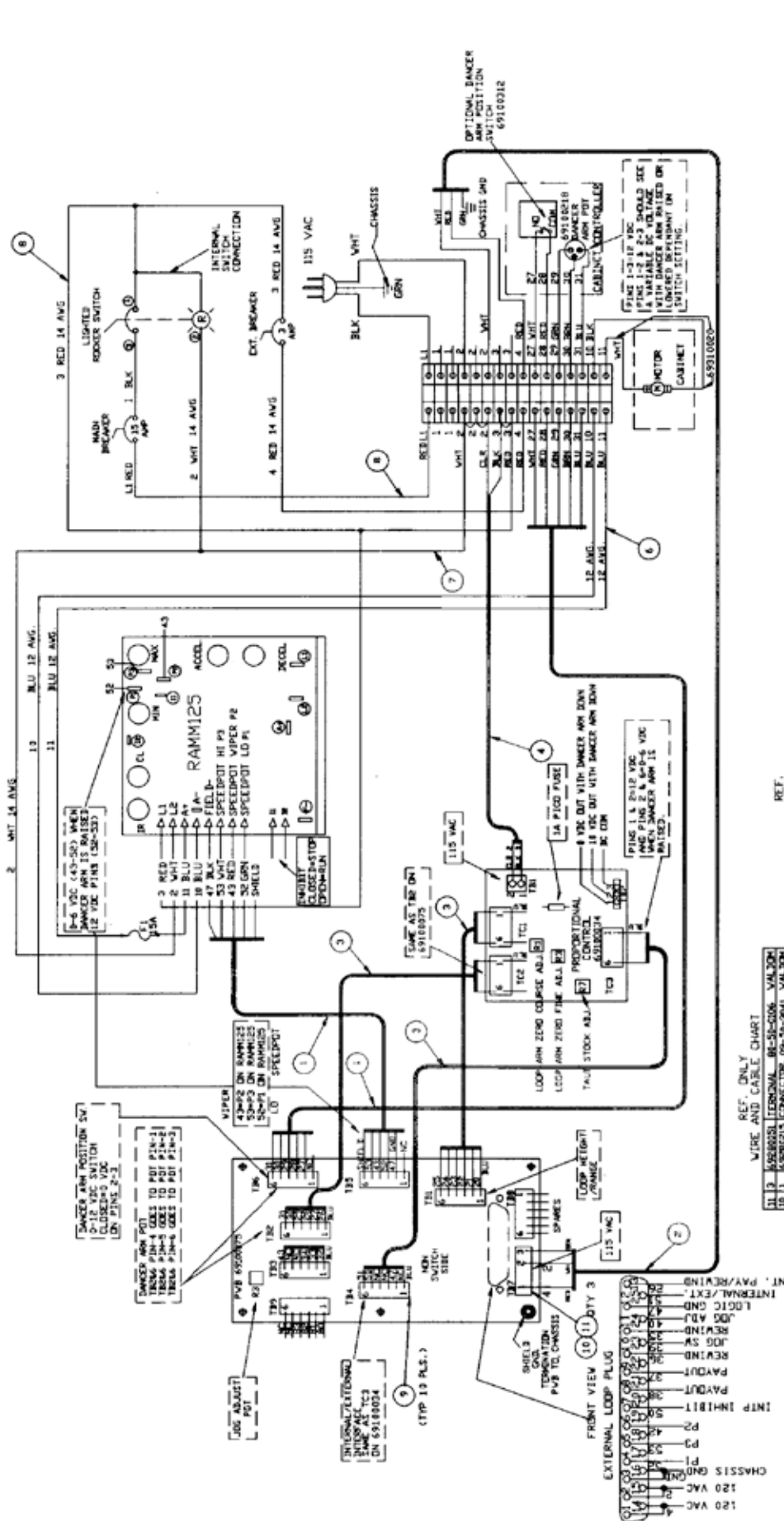

REF. ONLY

WIRE AND CABLE CHART

NO.	DESCRIPTION	TERMINAL	NO.	DESCRIPTION	VAL. ZON.
1	115 VAC	115	1	115 VAC	115
2	120 VAC	120	2	120 VAC	120
3	120 VAC	120	3	120 VAC	120
4	120 VAC	120	4	120 VAC	120
5	120 VAC	120	5	120 VAC	120
6	120 VAC	120	6	120 VAC	120
7	120 VAC	120	7	120 VAC	120
8	120 VAC	120	8	120 VAC	120
9	120 VAC	120	9	120 VAC	120
10	120 VAC	120	10	120 VAC	120
11	120 VAC	120	11	120 VAC	120
12	120 VAC	120	12	120 VAC	120

REF. ONLY

WIRE AND CABLE CHART

NO.	DESCRIPTION	TERMINAL	NO.	DESCRIPTION	VAL. ZON.
1	115 VAC	115	1	115 VAC	115
2	120 VAC	120	2	120 VAC	120
3	120 VAC	120	3	120 VAC	120
4	120 VAC	120	4	120 VAC	120
5	120 VAC	120	5	120 VAC	120
6	120 VAC	120	6	120 VAC	120
7	120 VAC	120	7	120 VAC	120
8	120 VAC	120	8	120 VAC	120
9	120 VAC	120	9	120 VAC	120
10	120 VAC	120	10	120 VAC	120
11	120 VAC	120	11	120 VAC	120
12	120 VAC	120	12	120 VAC	120

3-HALF

RAPID-AIR CORPORATION  
ROCKFORD, ILLINOIS 61102

WIRING DIAGRAM FOR STD SPEED STRAIGHTENERS (1-HP)

DATE	11/11/71	REV.	1
BY	W. J. HALL	CHKD BY	W. J. HALL
APP'D BY		DATE	11/11/71
REV.		NO.	85500246



# Wiring Diagram for Medium Speed Straighteners (2-HP)

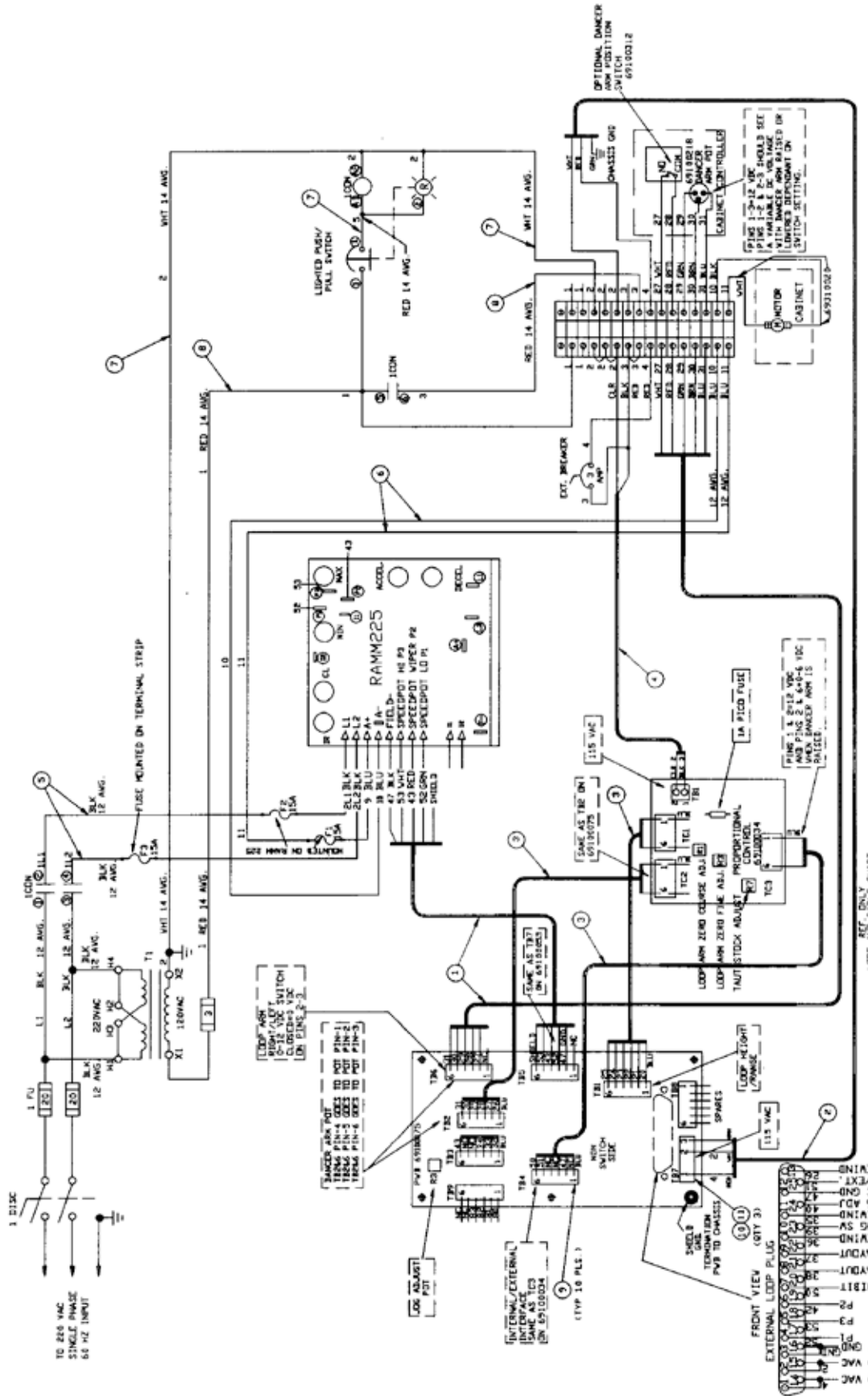

**RAPID-AIR CORPORATION**  
 4000 W. 11th St., Minneapolis, MN 55410  
 (612) 835-1111

Model No.	85500247
Serial No.	
Rev.	D

Wiring Diagram	85500247
Part No.	
Quantity	
Notes	

WIRE AWG	14
WIRE TYPE	THHN
WIRE COLOR	RED
WIRE SIZE	14
WIRE TYPE	THHN
WIRE COLOR	RED
WIRE SIZE	14

(2) FUSES 1 FOR DC FUSING & 1 FOR AC FUSING

**WIRE AWG ONLY CHART**

AWG	14	12	10	8	6	4	3	2	1
MM	2.0	2.6	3.2	4.0	5.0	6.4	8.0	10.0	12.7
CM	0.08	0.10	0.13	0.16	0.20	0.25	0.32	0.40	0.50



# Standard Speed SBX Series 4" Straightener

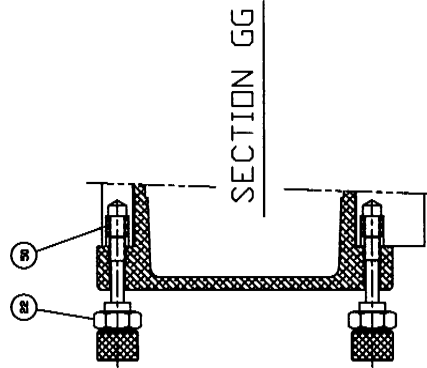
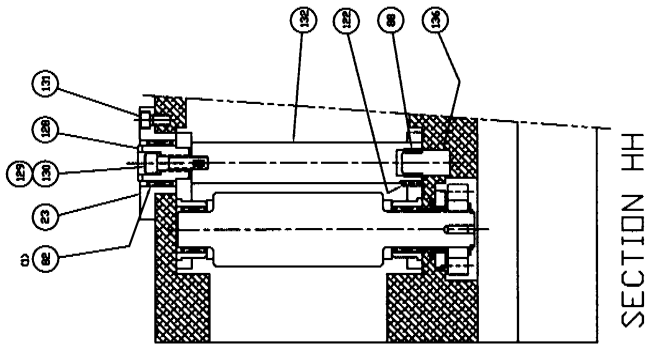
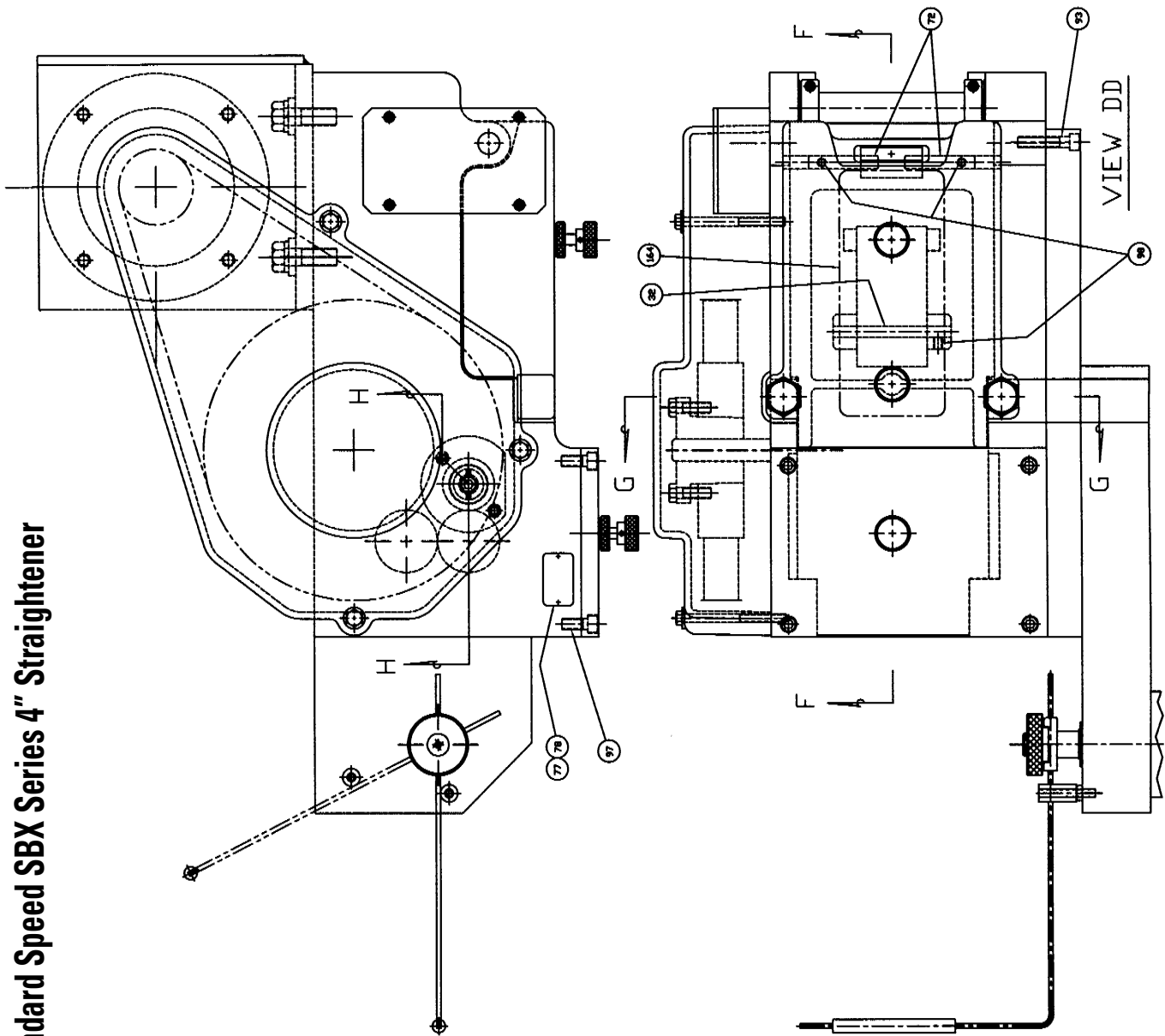

SHEET 2 OF 4

RAPID-AIR CORPORATION	
LANSING, MICHIGAN	
STANDARD SPEED	
SBX SERIES 4" STRAIGHTENER	
REV.	DATE
1	10-15-54
2	11-15-54
3	12-15-54
4	1-15-55
5	2-15-55
6	3-15-55
7	4-15-55
8	5-15-55
9	6-15-55
10	7-15-55
11	8-15-55
12	9-15-55
13	10-15-55
14	11-15-55
15	12-15-55
16	1-15-56
17	2-15-56
18	3-15-56
19	4-15-56
20	5-15-56
21	6-15-56
22	7-15-56
23	8-15-56
24	9-15-56
25	10-15-56
26	11-15-56
27	12-15-56
28	1-15-57
29	2-15-57
30	3-15-57
31	4-15-57
32	5-15-57
33	6-15-57
34	7-15-57
35	8-15-57
36	9-15-57
37	10-15-57
38	11-15-57
39	12-15-57
40	1-15-58
41	2-15-58
42	3-15-58
43	4-15-58
44	5-15-58
45	6-15-58
46	7-15-58
47	8-15-58
48	9-15-58
49	10-15-58
50	11-15-58
51	12-15-58
52	1-15-59
53	2-15-59
54	3-15-59
55	4-15-59
56	5-15-59
57	6-15-59
58	7-15-59
59	8-15-59
60	9-15-59
61	10-15-59
62	11-15-59
63	12-15-59
64	1-16-60
65	2-16-60
66	3-16-60
67	4-16-60
68	5-16-60
69	6-16-60
70	7-16-60
71	8-16-60
72	9-16-60
73	10-16-60
74	11-16-60
75	12-16-60
76	1-17-61
77	2-17-61
78	3-17-61
79	4-17-61
80	5-17-61
81	6-17-61
82	7-17-61
83	8-17-61
84	9-17-61
85	10-17-61
86	11-17-61
87	12-17-61
88	1-18-62
89	2-18-62
90	3-18-62
91	4-18-62
92	5-18-62
93	6-18-62
94	7-18-62
95	8-18-62
96	9-18-62
97	10-18-62
98	11-18-62
99	12-18-62
100	1-19-63
101	2-19-63
102	3-19-63
103	4-19-63
104	5-19-63
105	6-19-63
106	7-19-63
107	8-19-63
108	9-19-63
109	10-19-63
110	11-19-63
111	12-19-63
112	1-20-64
113	2-20-64
114	3-20-64
115	4-20-64
116	5-20-64
117	6-20-64
118	7-20-64
119	8-20-64
120	9-20-64
121	10-20-64
122	11-20-64
123	12-20-64
124	1-21-65
125	2-21-65
126	3-21-65
127	4-21-65
128	5-21-65
129	6-21-65
130	7-21-65
131	8-21-65
132	9-21-65
133	10-21-65
134	11-21-65
135	12-21-65
136	1-22-66
137	2-22-66
138	3-22-66
139	4-22-66
140	5-22-66
141	6-22-66
142	7-22-66
143	8-22-66
144	9-22-66
145	10-22-66
146	11-22-66
147	12-22-66
148	1-23-67
149	2-23-67
150	3-23-67
151	4-23-67
152	5-23-67
153	6-23-67
154	7-23-67
155	8-23-67
156	9-23-67
157	10-23-67
158	11-23-67
159	12-23-67
160	1-24-68
161	2-24-68
162	3-24-68
163	4-24-68
164	5-24-68
165	6-24-68
166	7-24-68
167	8-24-68
168	9-24-68
169	10-24-68
170	11-24-68
171	12-24-68
172	1-25-69
173	2-25-69
174	3-25-69
175	4-25-69
176	5-25-69
177	6-25-69
178	7-25-69
179	8-25-69
180	9-25-69
181	10-25-69
182	11-25-69
183	12-25-69
184	1-26-70
185	2-26-70
186	3-26-70
187	4-26-70
188	5-26-70
189	6-26-70
190	7-26-70
191	8-26-70
192	9-26-70
193	10-26-70
194	11-26-70
195	12-26-70
196	1-27-71
197	2-27-71
198	3-27-71
199	4-27-71
200	5-27-71
201	6-27-71
202	7-27-71
203	8-27-71
204	9-27-71
205	10-27-71
206	11-27-71
207	12-27-71
208	1-28-72
209	2-28-72
210	3-28-72
211	4-28-72
212	5-28-72
213	6-28-72
214	7-28-72
215	8-28-72
216	9-28-72
217	10-28-72
218	11-28-72
219	12-28-72
220	1-29-73
221	2-29-73
222	3-29-73
223	4-29-73
224	5-29-73
225	6-29-73
226	7-29-73
227	8-29-73
228	9-29-73
229	10-29-73
230	11-29-73
231	12-29-73
232	1-30-74
233	2-30-74
234	3-30-74
235	4-30-74
236	5-30-74
237	6-30-74
238	7-30-74
239	8-30-74
240	9-30-74
241	10-30-74
242	11-30-74
243	12-30-74
244	1-31-75
245	2-31-75
246	3-31-75
247	4-31-75
248	5-31-75
249	6-31-75
250	7-31-75
251	8-31-75
252	9-31-75
253	10-31-75
254	11-31-75
255	12-31-75
256	1-32-76
257	2-32-76
258	3-32-76
259	4-32-76
260	5-32-76
261	6-32-76
262	7-32-76
263	8-32-76
264	9-32-76
265	10-32-76
266	11-32-76
267	12-32-76
268	1-33-77
269	2-33-77
270	3-33-77
271	4-33-77
272	5-33-77
273	6-33-77
274	7-33-77
275	8-33-77
276	9-33-77
277	10-33-77
278	11-33-77
279	12-33-77
280	1-34-78
281	2-34-78
282	3-34-78
283	4-34-78
284	5-34-78
285	6-34-78
286	7-34-78
287	8-34-78
288	9-34-78
289	10-34-78
290	11-34-78
291	12-34-78
292	1-35-79
293	2-35-79
294	3-35-79
295	4-35-79
296	5-35-79
297	6-35-79
298	7-35-79
299	8-35-79
300	9-35-79
301	10-35-79
302	11-35-79
303	12-35-79
304	1-36-80
305	2-36-80
306	3-36-80
307	4-36-80
308	5-36-80
309	6-36-80
310	7-36-80
311	8-36-80
312	9-36-80
313	10-36-80
314	11-36-80
315	12-36-80
316	1-37-81
317	2-37-81
318	3-37-81
319	4-37-81
320	5-37-81
321	6-37-81
322	7-37-81
323	8-37-81
324	9-37-81
325	10-37-81
326	11-37-81
327	12-37-81
328	1-38-82
329	2-38-82
330	3-38-82
331	4-38-82
332	5-38-82
333	6-38-82
334	7-38-82
335	8-38-82
336	9-38-82
337	10-38-82
338	11-38-82
339	12-38-82
340	1-39-83
341	2-39-83
342	3-39-83
343	4-39-83
344	5-39-83
345	6-39-83
346	7-39-83
347	8-39-83
348	9-39-83
349	10-39-83
350	11-39-83
351	12-39-83
352	1-40-84
353	2-40-84
354	3-40-84
355	4-40-84
356	5-40-84
357	6-40-84
358	7-40-84
359	8-40-84
360	9-40-84
361	10-40-84
362	11-40-84
363	12-40-84
364	1-41-85
365	2-41-85
366	3-41-85
367	4-41-85
368	5-41-85
369	6-41-85

# Standard Speed SBX Series 4" Straightener

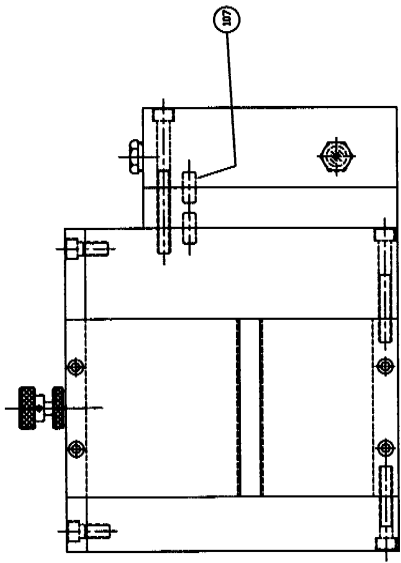

VIEW II

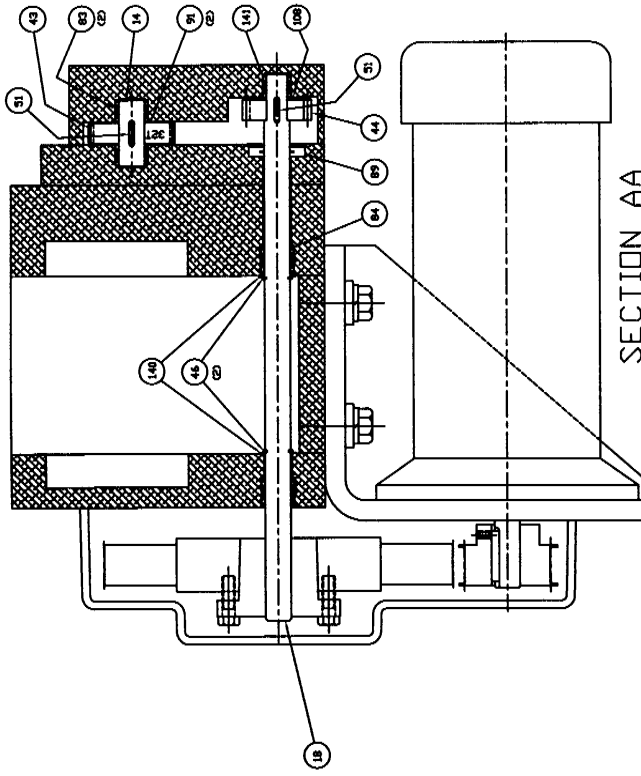

SECTION AA

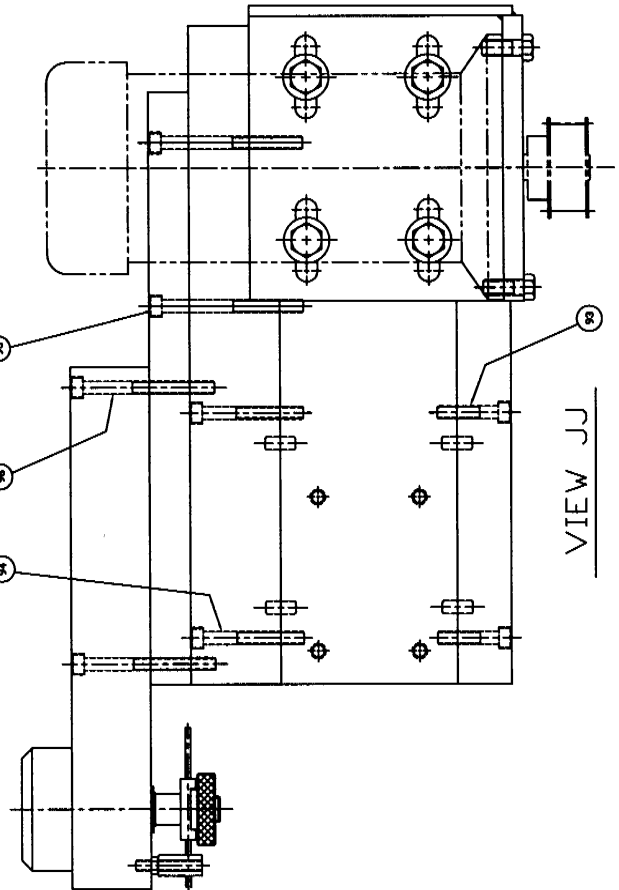

VIEW JJ

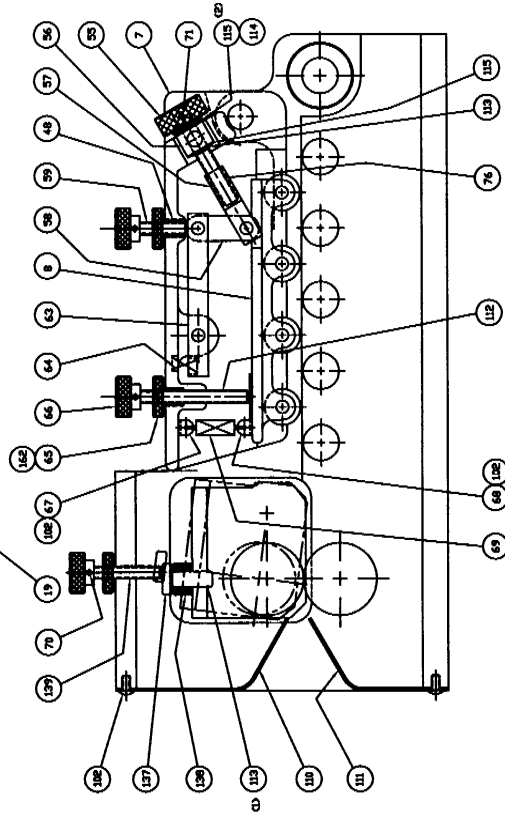

SECTION FF

PAPER-LESS CORPORATION	
2200 W. 10TH AVENUE	
DENVER, COLORADO 80202	
SERIES 4" STRAIGHTENER	
447	REV. 11-78
5	28-00014
6	E

SHEET 3 OF 4

# Standard Speed SBX Series 4" Straightener

ITEM NO.	DESCRIPTION	QTY
156	32900705 POT. MTS. SHAF.	
157	66004038 RHS 84-40 X 3/8	
158	69400005 MOTOR CLEAT	
159	69100218 POT. ASSEMBLY	
160	34700052 WASHER	
161	34800016 NUT CLAMP	
162	34600038 ADAPTOR	
163	34300056 DAMPER ROLLER	
164	35800142 DAMPER	
165	60910075 RETAINING RING	
166	64500018 THRUST WASHER	
167	33800109 LOCATING PIN	
168	64500063 NEEDLE BRG. JTT-1414	
169	36800019 KEY 3/16 X 1/2	
170	64500015 NEEDLE BRG. B-88	
171	34700051 WASHER	
172	36100068 ADJUSTING SCREW	
173	37500057 SPRING RETAINER SHAF.	
174	32900636 SPRING RETAINER SHAF.	
175	32900727 LABEL	
176	69000030 MOTOR 3/4 HP	
177	67410015 VALVE WASHER	
178	32900723 SPACER SHAF.	
179	65950050 SHCS 1/4-20 X 1/2	
180	61200031 LOCKWASHER 5/16	
181	66700064 BCS 5/8-8 X 1 1/4 VARDROLL	
182	32900685 ECCENTRIC SHAF.	
183	69400048 THICK WASHER 1/2"	
184	61200050 LOCKWASHER 1/2"	
185	31700842 SEAL PLATE	
186	61200019 FLAT WASHER 1/4"	
187	66800046 OIL SEAL - INITIAL 89763	
188	62100030 JOVEL PIN	
189	64000218 TYP RING	
190	64000212 TYP RING	
191	34700100 SPACER	
192	32900655 NEEDLE BRG. WASHING	
193	34100082 SPACER	
194	34100083 SPACER	
195	64500010 THRUST WASHER	
196	67410008 VALVE WASHER	
197	60910077 RETAINING RING	
198	35700016 STUD	
199	31400479 LOWER FRONT GUARD	
200	31400478 UPPER FRONT GUARD	
201	34800026 GEAR OTE	
202	64500012 THRUST WASHER	
203	64330075 DVAL PIN 5/16 X 3/4	
204	65850150 HEX BOLT 1/2-13 X 1 1/2	
205	65850150 HEX BOLT 3/8-16 X 1	
206	65850200 HEX BOLT 1/4-20 X 1 1/2	
207	64100043 WASHING 8AA-1005-7	
208	64610037 BRCS 810-32 X 3/8	
209	65950150 SHCS 3/8-16 X 1/2	
210	64210025 SET SCREW	
211	64210025 SET SCREW	
212	65950175 SHCS 5/16-18 X 3/4	
213	65950325 SHCS 5/16-18 X 3/4	
214	65950250 SHCS 5/16-18 X 1/2	
215	65950150 SHCS 5/16-18 X 1/2	
216	34700064 THRUST WASHER	
217	64500008 THRUST WASHER	
218	60800019 OIL SEAL C/P 8573	
219	64500062 NEEDLE BRG. JTT-87	
220	64500041 NEEDLE BRG. B-44E	
221	64500051 NEEDLE BRG. JTT-99	
222	64500057 NEEDLE BRG. JTT-1014	
223	64500057 NEEDLE BRG. JTT-1012	
224	64500061 NEEDLE BRG. B-108	
225	64500061 NEEDLE BRG. JTT-1410	
226	64500061 NEEDLE BRG. B-148	
227	64500063 NEEDLE BRG. B-1012	
228	32900645 RAPID-AIR LIQD	

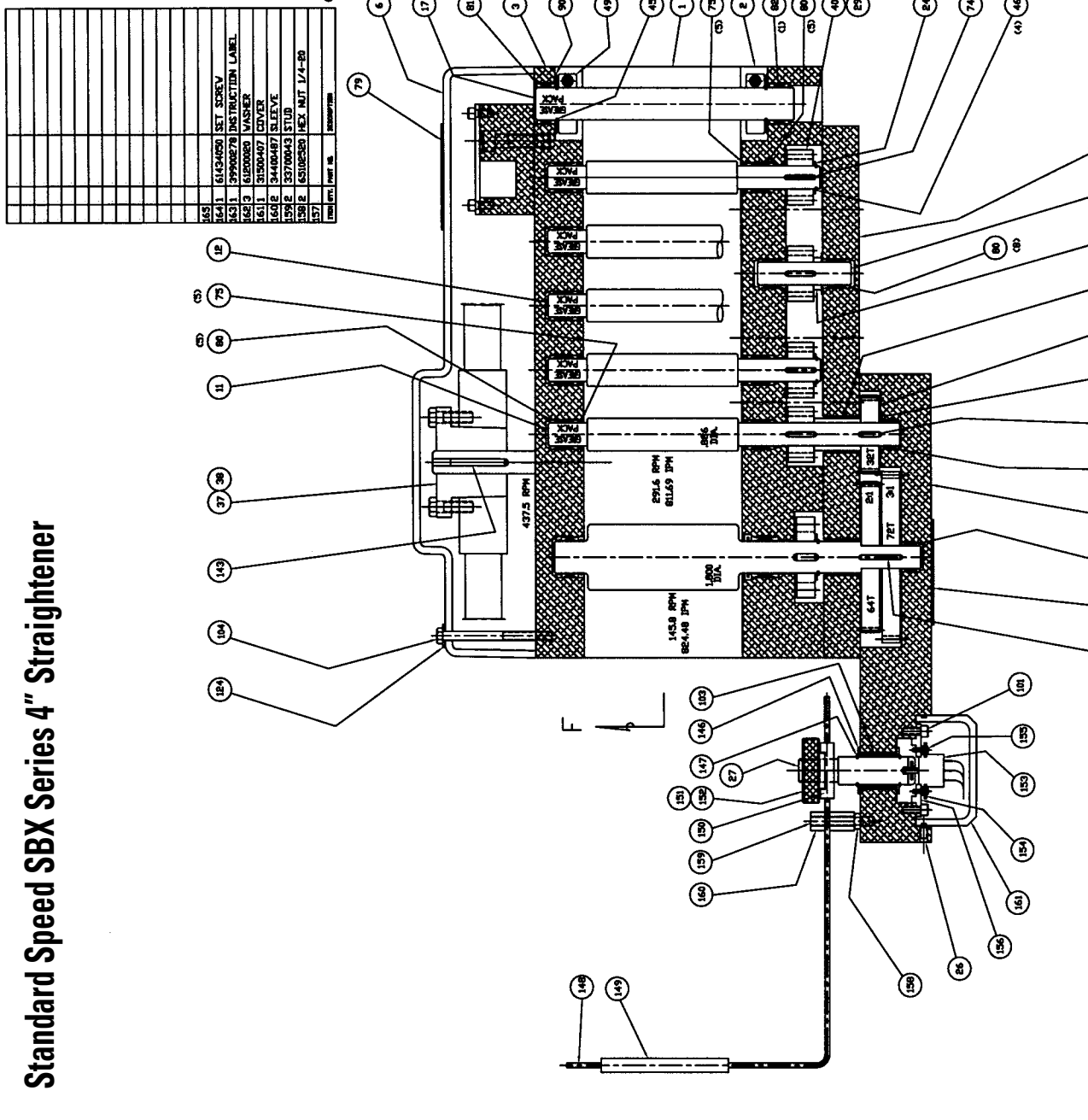

DRIVE ROLLS ARE 1/2" SLOWER THAN PINCH ROLLS

## SECTION BB

ITEM NO.	DESCRIPTION	QTY
77	16650050 DRIVE SCREW	
78	39900051 NAME PLATE	
79	32700017 HEX. ALL SCREW	
80	16800043 OIL SEAL	
81	32900018 DRIVE PIN	
82	66250100 PULL ROVEL	
83	66250750 PULL ROVEL	
84	16841816 ROLL PIN	
85	16841816 ROLL PIN	
86	37500050 SPRING	
87	31900415 BOTTOM SPRING ANCHOR	
88	31900415 TOP SPRING ANCHOR	
89	36700017 ALL KNOB	
90	36500018 KNULED LOCKNUT	
91	37500049 SPRING	
92	31701852 UPPER LINK	
93	69400010 KEAHTHER	
94	67700001 OIL SIGN	
95	63158375 PIPE PLUG 3/8 NPT	
96	32700015 STUD	
97	31701851 LINK	
98	31900415 HEX. ALL BLDCK	
99	31900415 PIVOT BLDCK	
100	36700018 ALL KNOB	
101	32900020 IDLER SHAF.	
102	36800005 KEY	
103	37500051 SPRING	
104	36800020 KEY	
105	65600064 THREADED INSERT	
106	34300090 COLLAR STAFFORD 67.6X3	
107	65600007 THREADED INSERT	
108	66910021 RETAINING RING	
109	66910062 RETAINING RING	
110	66910067 RETAINING RING	
111	32640010 SPAR GEAR 24T	
112	32640010 SPAR GEAR 24T	
113	32640010 SPAR GEAR 24T	
114	32640010 SPAR GEAR 24T	
115	32640010 SPAR GEAR 24T	
116	32640010 SPAR GEAR 24T	
117	32640010 SPAR GEAR 24T	
118	32640010 SPAR GEAR 24T	
119	32640010 SPAR GEAR 24T	
120	32640010 SPAR GEAR 24T	
121	32640010 SPAR GEAR 24T	
122	32640010 SPAR GEAR 24T	
123	32640010 SPAR GEAR 24T	
124	32640010 SPAR GEAR 24T	
125	32640010 SPAR GEAR 24T	
126	32640010 SPAR GEAR 24T	
127	32640010 SPAR GEAR 24T	
128	32640010 SPAR GEAR 24T	
129	32640010 SPAR GEAR 24T	
130	32640010 SPAR GEAR 24T	
131	32640010 SPAR GEAR 24T	
132	32640010 SPAR GEAR 24T	
133	32640010 SPAR GEAR 24T	
134	32640010 SPAR GEAR 24T	
135	32640010 SPAR GEAR 24T	
136	32640010 SPAR GEAR 24T	
137	32640010 SPAR GEAR 24T	
138	32640010 SPAR GEAR 24T	
139	32640010 SPAR GEAR 24T	
140	32640010 SPAR GEAR 24T	
141	32640010 SPAR GEAR 24T	
142	32640010 SPAR GEAR 24T	
143	32640010 SPAR GEAR 24T	
144	32640010 SPAR GEAR 24T	
145	32640010 SPAR GEAR 24T	
146	32640010 SPAR GEAR 24T	
147	32640010 SPAR GEAR 24T	
148	32640010 SPAR GEAR 24T	
149	32640010 SPAR GEAR 24T	
150	32640010 SPAR GEAR 24T	
151	32640010 SPAR GEAR 24T	
152	32640010 SPAR GEAR 24T	
153	32640010 SPAR GEAR 24T	
154	32640010 SPAR GEAR 24T	
155	32640010 SPAR GEAR 24T	
156	32640010 SPAR GEAR 24T	
157	32640010 SPAR GEAR 24T	
158	32640010 SPAR GEAR 24T	
159	32640010 SPAR GEAR 24T	
160	32640010 SPAR GEAR 24T	
161	32640010 SPAR GEAR 24T	
162	32640010 SPAR GEAR 24T	
163	32640010 SPAR GEAR 24T	
164	32640010 SPAR GEAR 24T	
165	32640010 SPAR GEAR 24T	
166	32640010 SPAR GEAR 24T	
167	32640010 SPAR GEAR 24T	
168	32640010 SPAR GEAR 24T	
169	32640010 SPAR GEAR 24T	
170	32640010 SPAR GEAR 24T	
171	32640010 SPAR GEAR 24T	
172	32640010 SPAR GEAR 24T	
173	32640010 SPAR GEAR 24T	
174	32640010 SPAR GEAR 24T	
175	32640010 SPAR GEAR 24T	
176	32640010 SPAR GEAR 24T	
177	32640010 SPAR GEAR 24T	
178	32640010 SPAR GEAR 24T	
179	32640010 SPAR GEAR 24T	
180	32640010 SPAR GEAR 24T	
181	32640010 SPAR GEAR 24T	
182	32640010 SPAR GEAR 24T	
183	32640010 SPAR GEAR 24T	
184	32640010 SPAR GEAR 24T	
185	32640010 SPAR GEAR 24T	
186	32640010 SPAR GEAR 24T	
187	32640010 SPAR GEAR 24T	
188	32640010 SPAR GEAR 24T	
189	32640010 SPAR GEAR 24T	
190	32640010 SPAR GEAR 24T	
191	32640010 SPAR GEAR 24T	
192	32640010 SPAR GEAR 24T	
193	32640010 SPAR GEAR 24T	
194	32640010 SPAR GEAR 24T	
195	32640010 SPAR GEAR 24T	
196	32640010 SPAR GEAR 24T	
197	32640010 SPAR GEAR 24T	
198	32640010 SPAR GEAR 24T	
199	32640010 SPAR GEAR 24T	
200	32640010 SPAR GEAR 24T	
201	32640010 SPAR GEAR 24T	
202	32640010 SPAR GEAR 24T	
203	32640010 SPAR GEAR 24T	
204	32640010 SPAR GEAR 24T	
205	32640010 SPAR GEAR 24T	
206	32640010 SPAR GEAR 24T	
207	32640010 SPAR GEAR 24T	
208	32640010 SPAR GEAR 24T	
209	32640010 SPAR GEAR 24T	
210	32640010 SPAR GEAR 24T	
211	32640010 SPAR GEAR 24T	
212	32640010 SPAR GEAR 24T	
213	32640010 SPAR GEAR 24T	
214	32640010 SPAR GEAR 24T	
215	32640010 SPAR GEAR 24T	
216	32640010 SPAR GEAR 24T	
217	32640010 SPAR GEAR 24T	
218	32640010 SPAR GEAR 24T	
219	32640010 SPAR GEAR 24T	
220	32640010 SPAR GEAR 24T	
221	32640010 SPAR GEAR 24T	
222	32640010 SPAR GEAR 24T	
223	32640010 SPAR GEAR 24T	
224	32640010 SPAR GEAR 24T	
225	32640010 SPAR GEAR 24T	
226	32640010 SPAR GEAR 24T	
227	32640010 SPAR GEAR 24T	
228	32640010 SPAR GEAR 24T	

RAPID-AIR CORPORATION  
STANDARD SPEED STRAIGHTENERS - SBX SERIES 4" STRAIGHTENER  
ITEM NO. 25-40014  
REV. 7

# SCX-6 Straightener Standard Speed

ITEM NO.	DESCRIPTION	QTY	UNIT	REF. NO.
157	6162460 SET SCREW			
158	6430028 THRU SHFT			
159	6430028 THRU SHFT			
160	6430028 THRU SHFT			
161	6430028 THRU SHFT			
162	6430028 THRU SHFT			
163	6430028 THRU SHFT			
164	6430028 THRU SHFT			
165	6430028 THRU SHFT			
166	6430028 THRU SHFT			
167	6430028 THRU SHFT			
168	6430028 THRU SHFT			
169	6430028 THRU SHFT			
170	6430028 THRU SHFT			
171	6430028 THRU SHFT			
172	6430028 THRU SHFT			
173	6430028 THRU SHFT			
174	6430028 THRU SHFT			
175	6430028 THRU SHFT			
176	6430028 THRU SHFT			
177	6430028 THRU SHFT			
178	6430028 THRU SHFT			
179	6430028 THRU SHFT			
180	6430028 THRU SHFT			
181	6430028 THRU SHFT			
182	6430028 THRU SHFT			
183	6430028 THRU SHFT			
184	6430028 THRU SHFT			
185	6430028 THRU SHFT			
186	6430028 THRU SHFT			
187	6430028 THRU SHFT			
188	6430028 THRU SHFT			
189	6430028 THRU SHFT			
190	6430028 THRU SHFT			
191	6430028 THRU SHFT			
192	6430028 THRU SHFT			
193	6430028 THRU SHFT			
194	6430028 THRU SHFT			
195	6430028 THRU SHFT			
196	6430028 THRU SHFT			
197	6430028 THRU SHFT			
198	6430028 THRU SHFT			
199	6430028 THRU SHFT			
200	6430028 THRU SHFT			

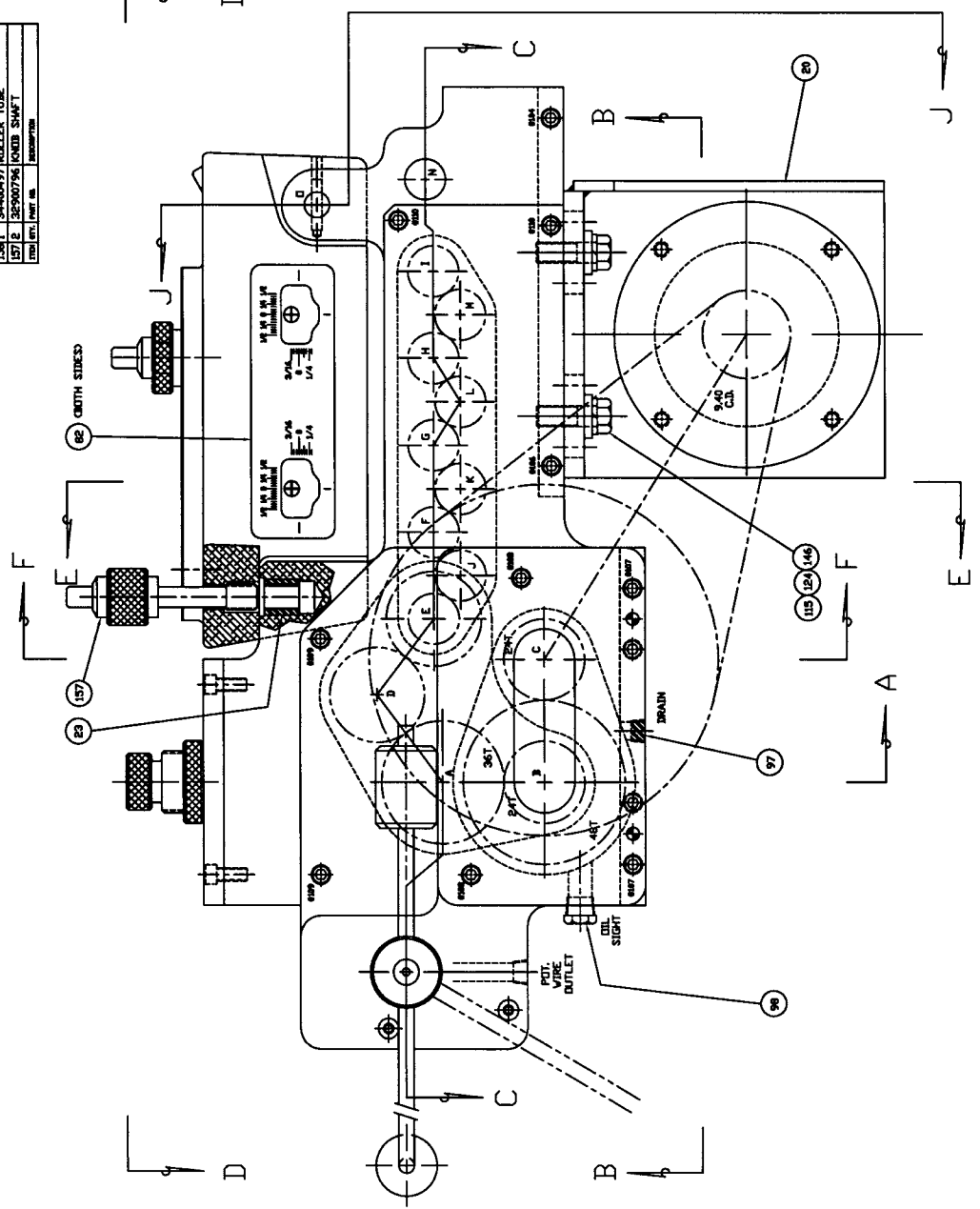

ITEM NO.	DESCRIPTION	QTY	UNIT	REF. NO.
151	3410057 SPACER			
152	3290075 PIVOT SHFT			
153	3701919 OIL SEAL PLATE			
154	6232075 NOVEL PIN			
155	3790098 NEEDLE BRG. BUSHING			
156	6741005 WAVE WASHER			
157	2110061 WRENCH ASSEMBLY			
158	3420061 LOCKNUT			
159	3610078 ADJ. SCREW			
160	6900002 FLAT WASHER 1/4"			
161	6100050 LOCK WASHER 1/2"			
162	3290068 ECCENTRIC SHFT			
163	6100020 TP RING			
164	6100020 TP RING			
165	6231007 NOVEL PIN 3/16 X 7/8			
166	3470010 SPACER			
167	3380100 LIDATING PIN			
168	6200053 OIL SEAL INTDIAL 6430098			
169	3010023 BELT COVER HOUSING			
170	3460015 WANCER ARM			
171	6510050 HEX NUT 1/4-20			
172	3440047 SLEEVES			
173	3770043 STUD			
174	6940009 MOTOR CLEAN			
175	6910020 POT. ASSY.			
176	3130047 COVER			
177	6430008 THRUST WASHER			
178	2010024 ECC. BRG. HSL.			
179	3140044 UPPER FRONT GUARD			
180	3140043 LOWER FRONT GUARD			
181	6410057 BUSHING 8A-1049-9			
182	6940068 THICK WASHER			
183	6100022 FLAT WASHER 3/16			
184	6120021 LOCKWASHER 3/16			
185	6504038 NMS 84-40 X 3/8			
186	6420023 SET SCREW			
187	6420023 SET SCREW			
188	6920075 SHCS 1/4-20 X 3/4			
189	6920075 SHCS 1/4-20 X 3/4			
190	6440027 NMS 84-32 X 3/8			
191	6920075 SHCS 1/4-20 X 3/4			
192	6920075 SHCS 1/4-20 X 3/4			
193	6920075 SHCS 1/4-20 X 3/4			
194	6920075 SHCS 1/4-20 X 3/4			
195	6920075 SHCS 1/4-20 X 3/4			
196	6920075 SHCS 1/4-20 X 3/4			
197	6920075 SHCS 1/4-20 X 3/4			
198	6920075 SHCS 1/4-20 X 3/4			
199	6920075 SHCS 1/4-20 X 3/4			
200	6920075 SHCS 1/4-20 X 3/4			

**RAPID-AIR CORPORATION**  
 1000 S. STANFORD BLVD. PHOENIX, AZ 85024  
 PHONE: (602) 998-1111 FAX: (602) 998-1112  
 WWW: WWW.RAPID-AIR.COM

SHEET 1 OF 6  
 DATE: 08/01/00  
 DRAWN BY: J. L. HARRIS  
 CHECKED BY: J. L. HARRIS  
 APPROVED BY: J. L. HARRIS

# SCX-6 Straightener Standard Speed

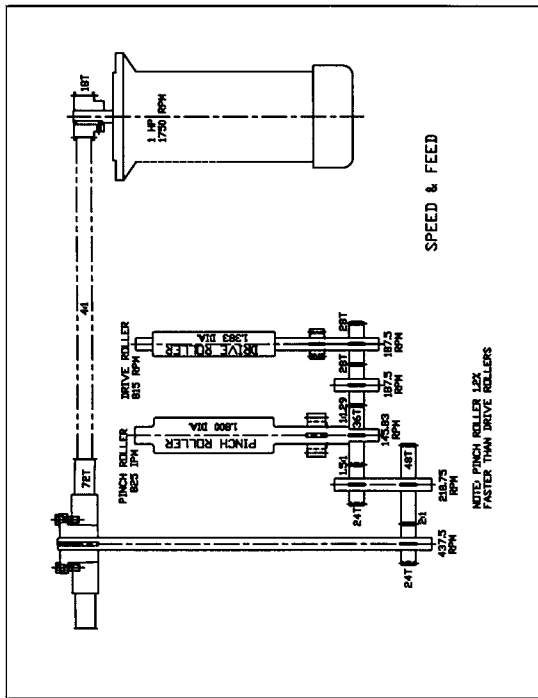

# SCX-6 Straightener Standard Speed

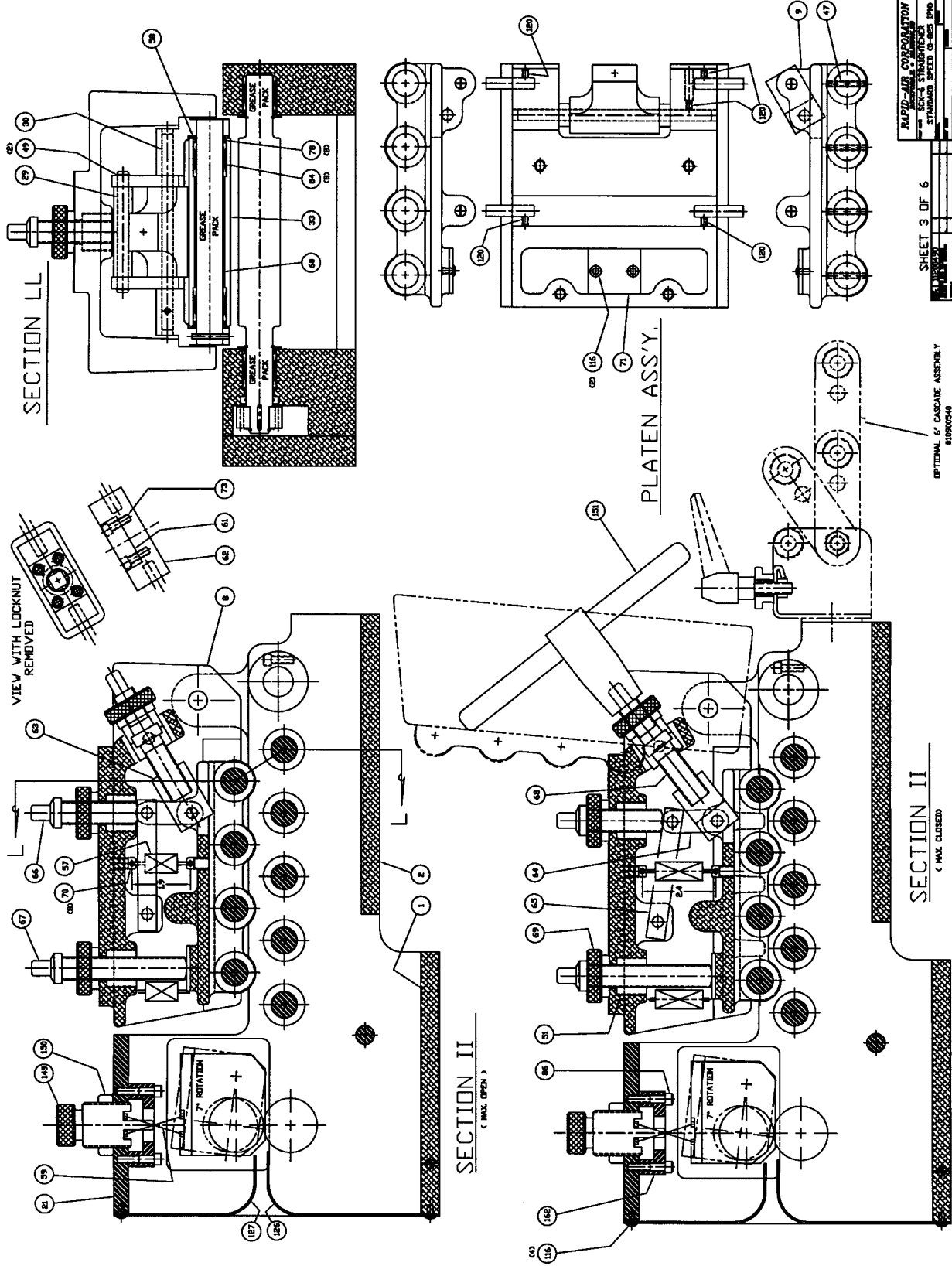

RAPID-AIR CORPORATION	
1100 W. 17th Street, Tulsa, Oklahoma 74119	
SCX-6 STRAIGHTENER	
STANDARD SPEED 0-250 IPD	
REV. 1	
DATE	BY
10/11/88	WJL
SCALE	AS SHOWN
DRWING NO.	88-000105
E	

# SCX-6 Straightener Standard Speed

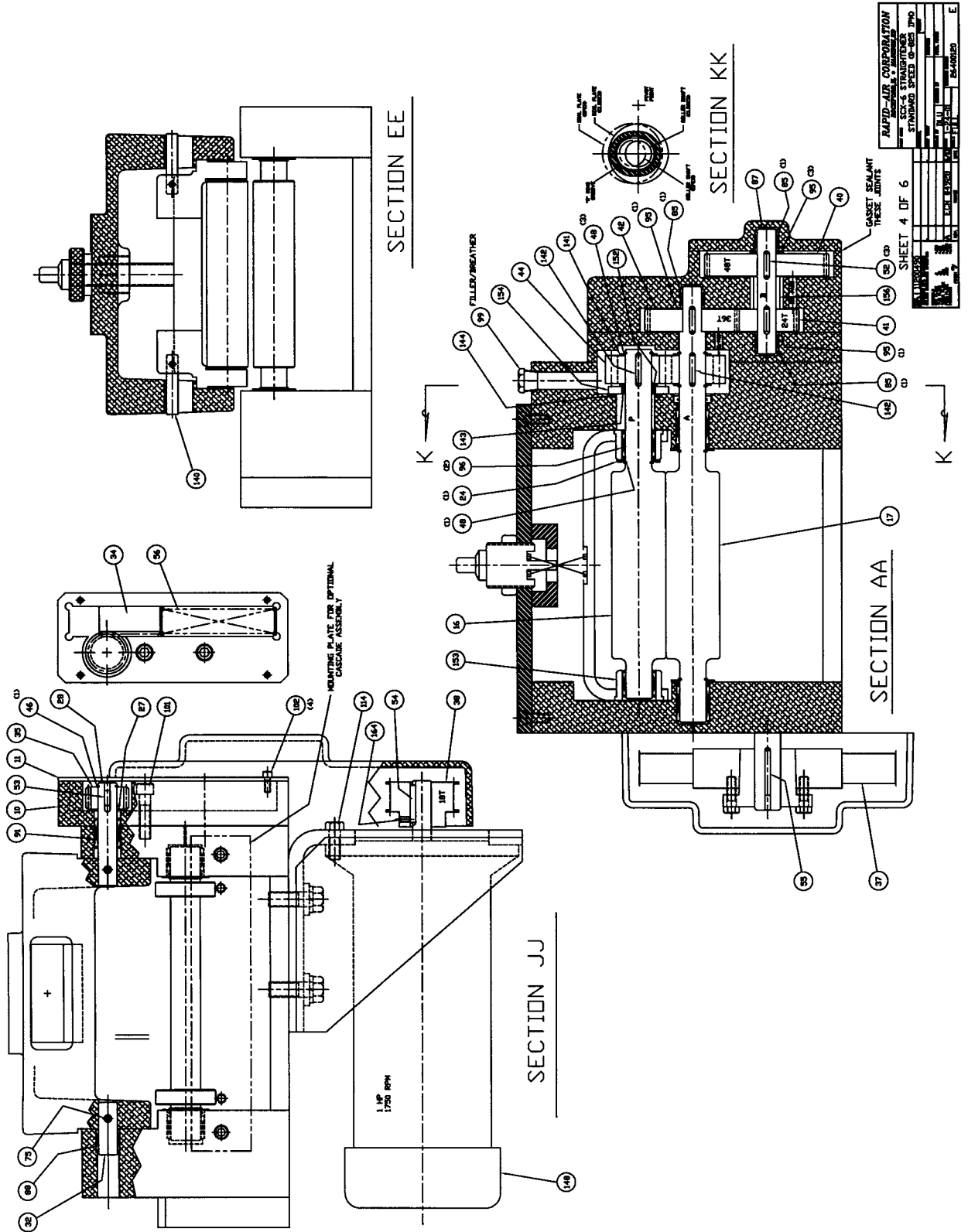

# SCX-6 Straightener Standard Speed

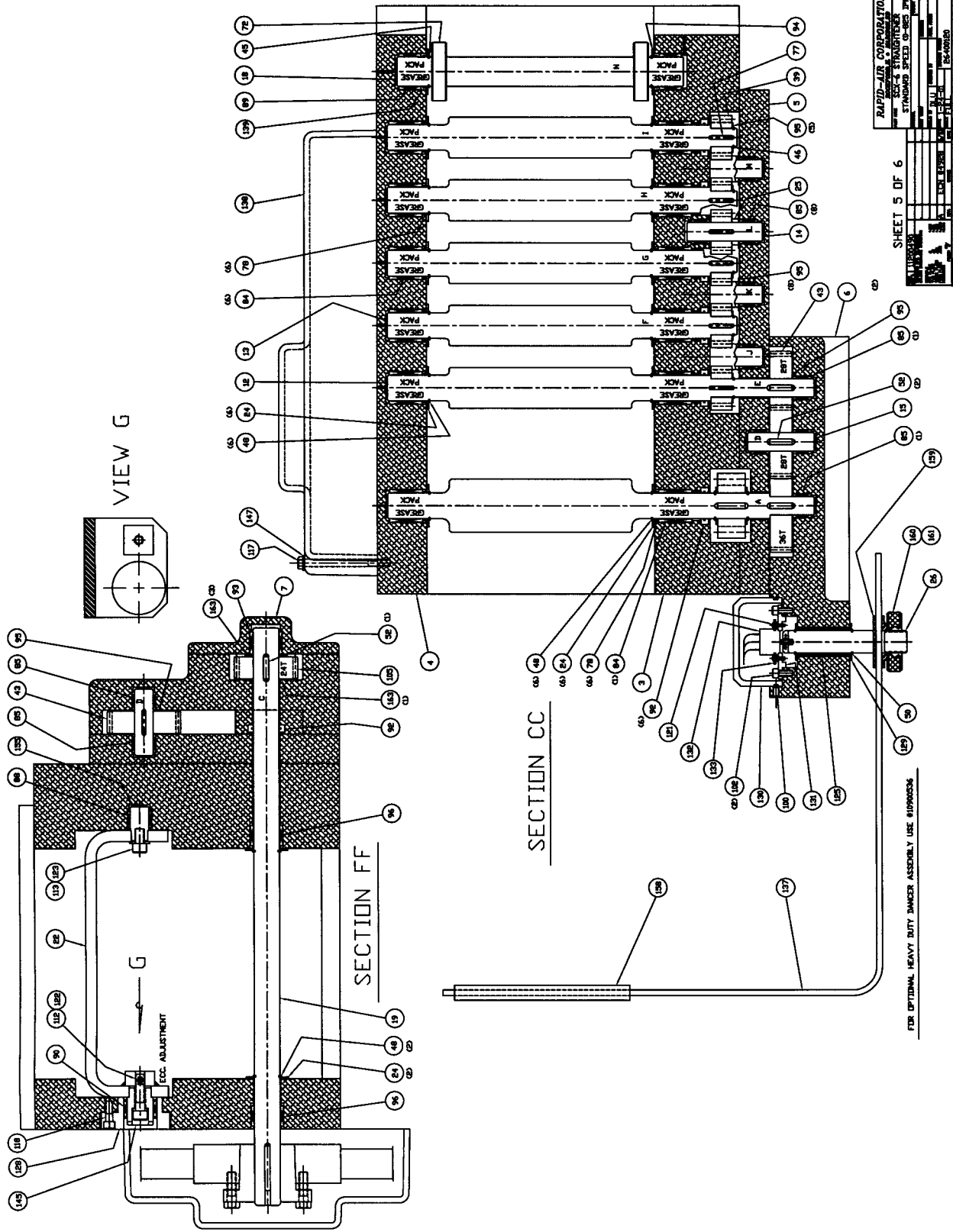

# SCX-6 Straightener Standard Speed

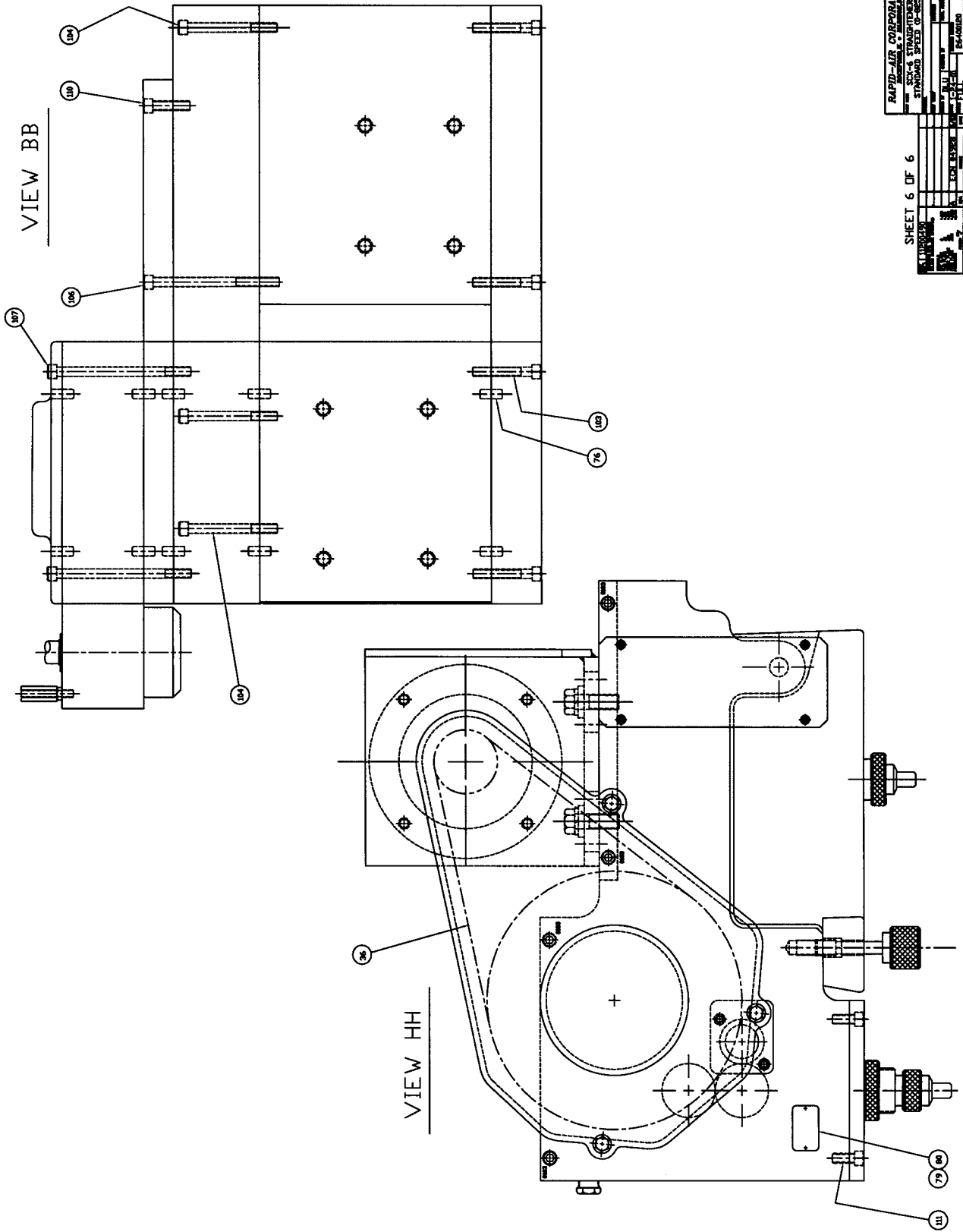

SHEET 6 OF 6

RAPID-AIR CORPORATION	
SCX-6 STRAIGHTENER	
STANDARD SPEED (0-85) RPM	
DATE	BY
CHKD BY	APP'D BY
REV	DESCRIPTION
1	AS SHOWN
2	REVISION
3	REVISION
4	REVISION
5	REVISION
6	REVISION
7	REVISION
8	REVISION
9	REVISION
10	REVISION
11	REVISION
12	REVISION
13	REVISION
14	REVISION
15	REVISION
16	REVISION
17	REVISION
18	REVISION
19	REVISION
20	REVISION
21	REVISION
22	REVISION
23	REVISION
24	REVISION
25	REVISION
26	REVISION
27	REVISION
28	REVISION
29	REVISION
30	REVISION
31	REVISION
32	REVISION
33	REVISION
34	REVISION
35	REVISION
36	REVISION
37	REVISION
38	REVISION
39	REVISION
40	REVISION
41	REVISION
42	REVISION
43	REVISION
44	REVISION
45	REVISION
46	REVISION
47	REVISION
48	REVISION
49	REVISION
50	REVISION
51	REVISION
52	REVISION
53	REVISION
54	REVISION
55	REVISION
56	REVISION
57	REVISION
58	REVISION
59	REVISION
60	REVISION
61	REVISION
62	REVISION
63	REVISION
64	REVISION
65	REVISION
66	REVISION
67	REVISION
68	REVISION
69	REVISION
70	REVISION
71	REVISION
72	REVISION
73	REVISION
74	REVISION
75	REVISION
76	REVISION
77	REVISION
78	REVISION
79	REVISION
80	REVISION
81	REVISION
82	REVISION
83	REVISION
84	REVISION
85	REVISION
86	REVISION
87	REVISION
88	REVISION
89	REVISION
90	REVISION
91	REVISION
92	REVISION
93	REVISION
94	REVISION
95	REVISION
96	REVISION
97	REVISION
98	REVISION
99	REVISION
100	REVISION

# Typical Stamping Layout

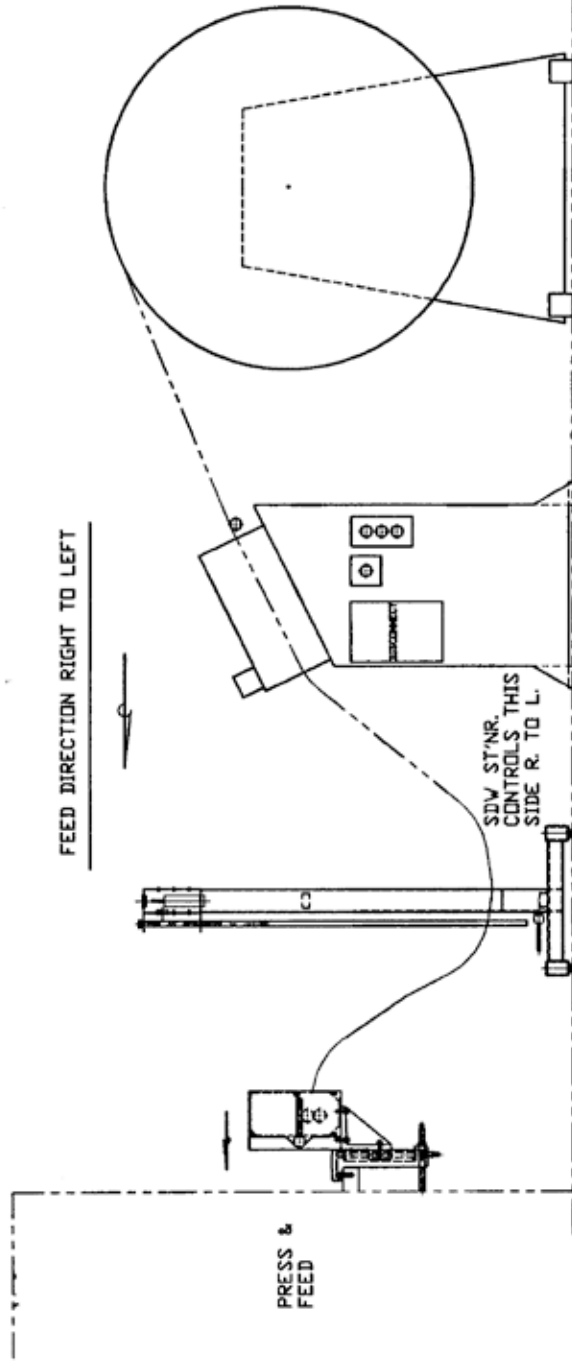
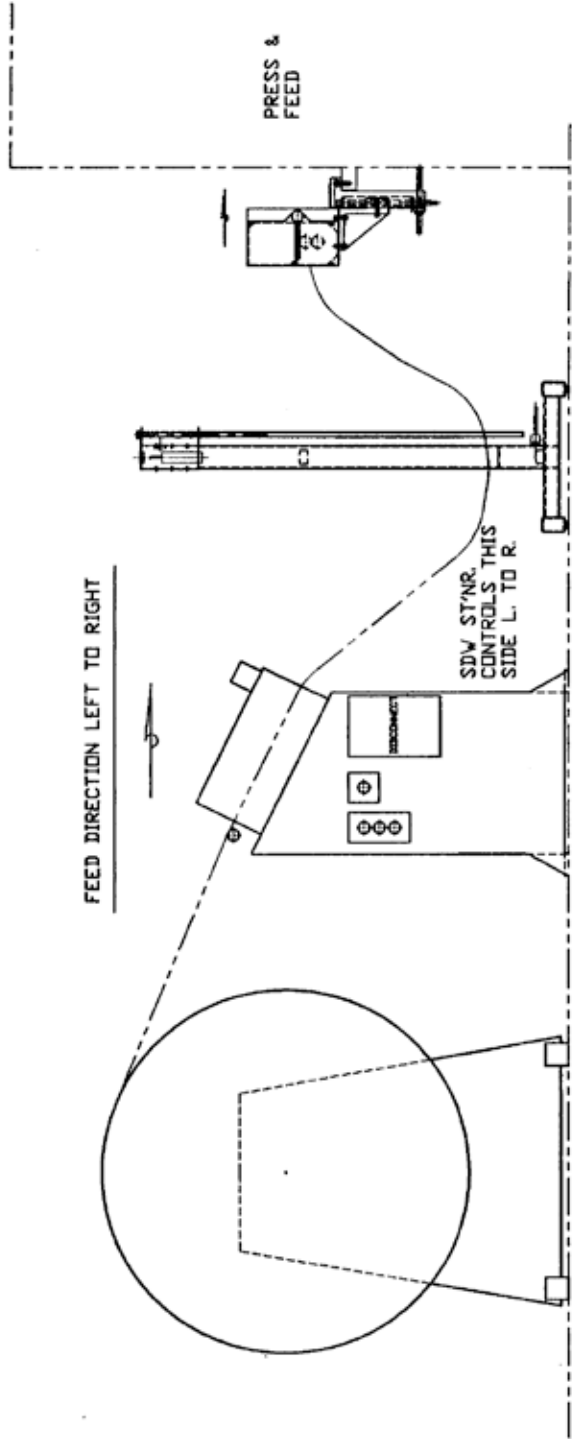

<b>RAPID-AIR CORPORATION</b> ROCKFORD, ILL. & MADISON, SD.	
PART NO. <b>RT-1</b> REV. <b>1/4</b>	CHECKED BY _____ DATE _____ DESIGNED BY _____ DATE _____
TO LEFT - PAYOUT LINE TO RIGHT - PAYOUT LINE	DRAWN BY _____ DATE _____
TITLE _____ DEPT. _____ PROJECT _____	SHEET NO. _____ OF _____

# STRAIGHTENER SA3 - SB4

---

## OPERATION

For set up only, place a short length of stock about four feet on the bottom rolls, between the pinch rolls. Set the entrance guide rolls before lowering the cover. Make sure the top rolls are retracted to prevent stock deformation. Apply light pinch roll force on the stock to insure adequate assisting pulling force on the stock and to prevent slippage of the stock over the straightener rolls. Never overload the pinch rolls. This could damage the stock by extrusion causing permanent deformation.

With the cover down and the stock in place, position the idler rolls such that they are mid-way between the drive rolls. The windows in the side of the cover are visual indicators of the idler rolls relative position to the drive rolls.

Do not lock the cover down at this time. With the cover held down firmly by hand, lower the vertical entrance knob until the first idler roll contacts

the stock with only slight deformation (crease) at the station. Observe the degree of deformation at this first station by lifting the cover and noting the pattern of light reflecting off the stock surface. Rotate the vertical entrance knob 1/4 turn down and lock in place.

Close the cover, hand hold in place while lowering the exit knob. Continuously observe the changing deformation pattern until all but the last station reflects a change. The stock should reflect a diminishing deformation pattern until the final set of exit rolls afford no deformation. Lock the exit knob. Close the cover and latch.

The dancer arm position for height and range is operator selectable through the settings of thumbwheels. The speed of the straightener rollers is automatically controlled by the position of the dancer arm. As the dancer arm is raised, the straightener rollers increase in speed. This minimizes starting and stopping and

resultant stock deformation.

**CAUTION:** Lateral adjustment, generally, requires no more than two or three turns either side of center. Never force idler rolls against the powered rolls. This will deform the stock.

## CAPACITY

The model SA3 is designed for 3" maximum width and .005 to .020 thick material. The SB4 is designed for 4" maximum width and .007 to .035 thick material. The maximum feed rate for SA3 and SB4 is 700 inches per minute. The maximum feed rate for SAM3 and SBM4 is 1400 inches per minute.

## ELECTRIC MOTOR

SA3 and SB4 straighteners are furnished with a 1/4 HP - 2500 RPM permanent magnet motor. Input power is single phase, 115 volt A.C. rotation must be CW as viewed from shaft end. SAM3 and SBM4 have a 1/2 HP motor.

# STRAIGHTENER SA3 - SB4

---

## Lubrication

Gear transmission oil - Use Mobil 2000 SSU 100 degree F 600W cylinder oil or equivalent.

SA3 & SB4 Worm Gear Case (above motor) 4 oz. capacity.

SA3 Spur Gear Case (straightener side) 4 oz. capacity.

SB4 Spur Gear Case (straightener side) 6 oz. capacity.

Change oil every 1000 hours.

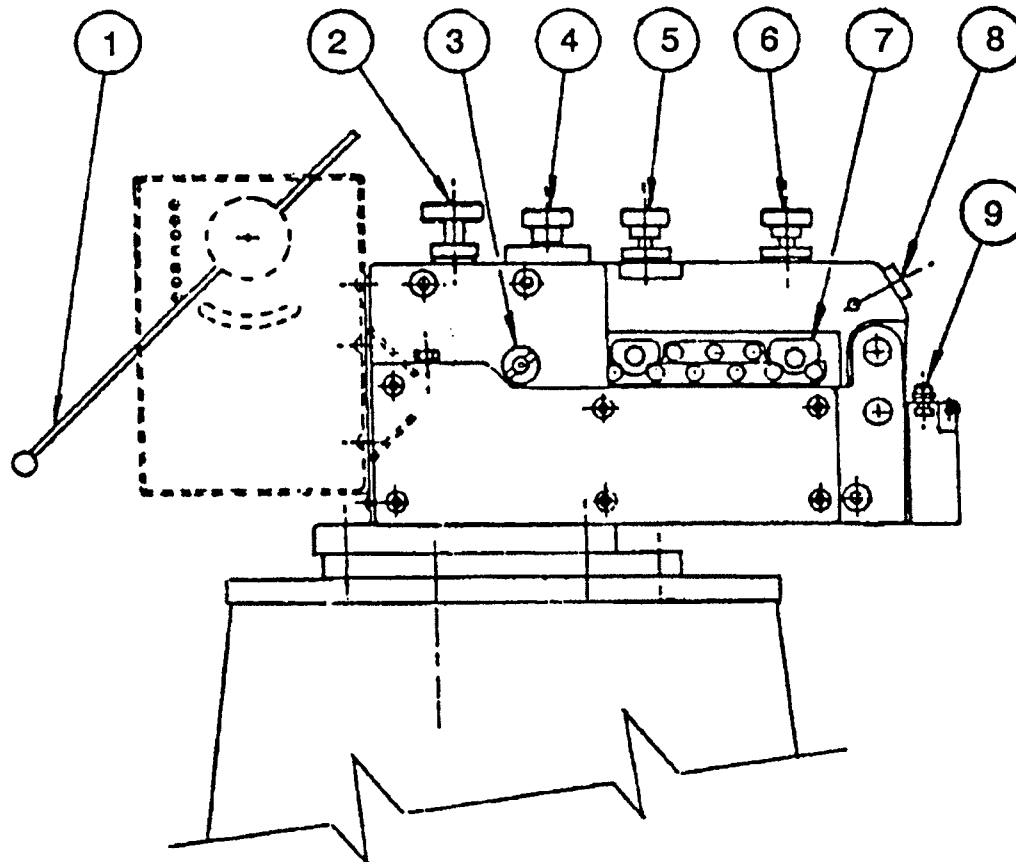

1. Loop Control Arm
2. Pinch Roll Knob
3. Eccentric Trunion
4. Cover Latch
5. Exit Adjustment Knob
6. Entrance Adjustment Knob
7. Visual Indicator Window
8. Lateral Adjustment Knob
9. Entrance Guide Rolls

# RAPID ROLL

---

## **OPERATION**

For set up only, place a short length of stock about four feet long on the bottom rolls, between the pinch rolls. Set the entrance guide rolls to maintain stock position. Make sure the top rolls are retracted. To prevent stock deformation apply light pinch roll force on the stock to insure adequate assisting pulling force on the stock and to prevent slippage of the stock while operating. Never overload the pinch rolls. This could damage the stock by extrusion causing permanent deformation.

The dancer arm position for height and range is operator selectable through the setting of thumbwheels.

The speed of the Rapid Roll rollers is automatically controlled by the position of the dancer arm.

As the dancer arm is raised the Rapid Roll rollers increase in speed. This minimizes starting and stopping and resultant stock deformation.

## **CAPACITY**

The model P1V is designed for 1.5" maximum width and .0005 to .075 thick material. The P4V is designed for 4" maximum width and .0005 - .060 thick material. The P8V is designed for 8" maximum width and .0005 - .050 thick material. The maximum feed rate for P1V, P4V & P8V is 700 inches per minute. The maximum feed rate for P1M-P8M is 1400 inches per minute.

## **ELECTRIC MOTOR**

P1V, P4V, and P8V Rapid Rolls are furnished with a 1/4 HP - 2500 RPM permanent magnet motor. Input power is single phase, 115 volt A.C. Rotation must be clockwise as viewed from shaft end. The P1M, P4M & P8M have a 1/2 HP motor.

## **LUBRICATION**

Gear transmission oil – Use Mobil 2000 SSU, 100 degree F 600 W cylinder oil or equivalent. Rapid Roll worm gear case (above motor) 4 oz. capacity (fill to level plug). Change every 1000 hours of operation.

## **GREASE FITTINGS**

Use Mobilux number 2 or equivalent.

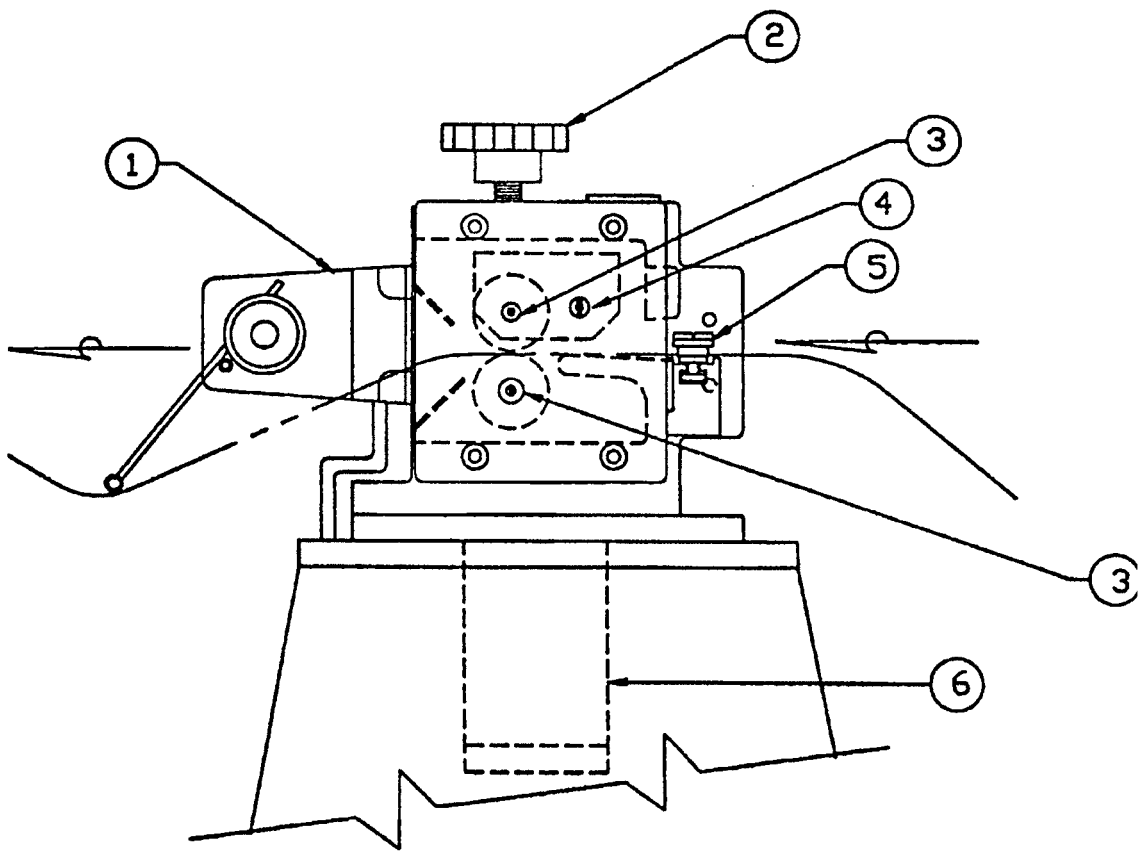

1. Loop Control Arm
2. Pinch Roll Knob
3. Grease Zircs
4. Eccentric Trunion
5. Entrance Guide Rollers
6. D.C. Drive Motor