



PALLET MASTER (PMD) OPERATING INSTRUCTIONS

MODELS

(INCLUDES PMD35 & PMD50. 115VAC, 1PH, 60HZ)

OPERATING INSTRUCTIONS

PMD 35 &50

INSTALLATION

The machine that you have just received was disassembled for shipping purposes. Please check all parts for shipping damage. If damage has occurred, contact the carrier first and then Rapid Air to report the damage.

Upon opening the shipping crate, you will find the main base table control arm, drum, and a counter weight. Release all the components from the hold down position and put them in the location that the pallet reel will be assembled.

Locate the electrical wires to determine where the control arm will be mounted. Attach the control arm to the table base with the (4) 1/2-13x3/4 hex head screws provided.

Remove the access cover of the control arm and route the electrical wires from the base into the electrical control area. Attach the wires to the terminals provided.

See fig. below.

If using 120 vac 1 phase input. Drawings 85500179 & 29100157 are the wiring diagrams.
 If using 220 vac 1 phase input. Drawings 85500178 & 29100158 are the wiring diagrams.
 If using 220 vac and a minarik drive then the drawings are 85500178 & 29100160 are the wiring diagrams.

The troubleshooting drawing can be used for all circuit checks.

The figure "Reel Man 7" is a typical layout pictorial.

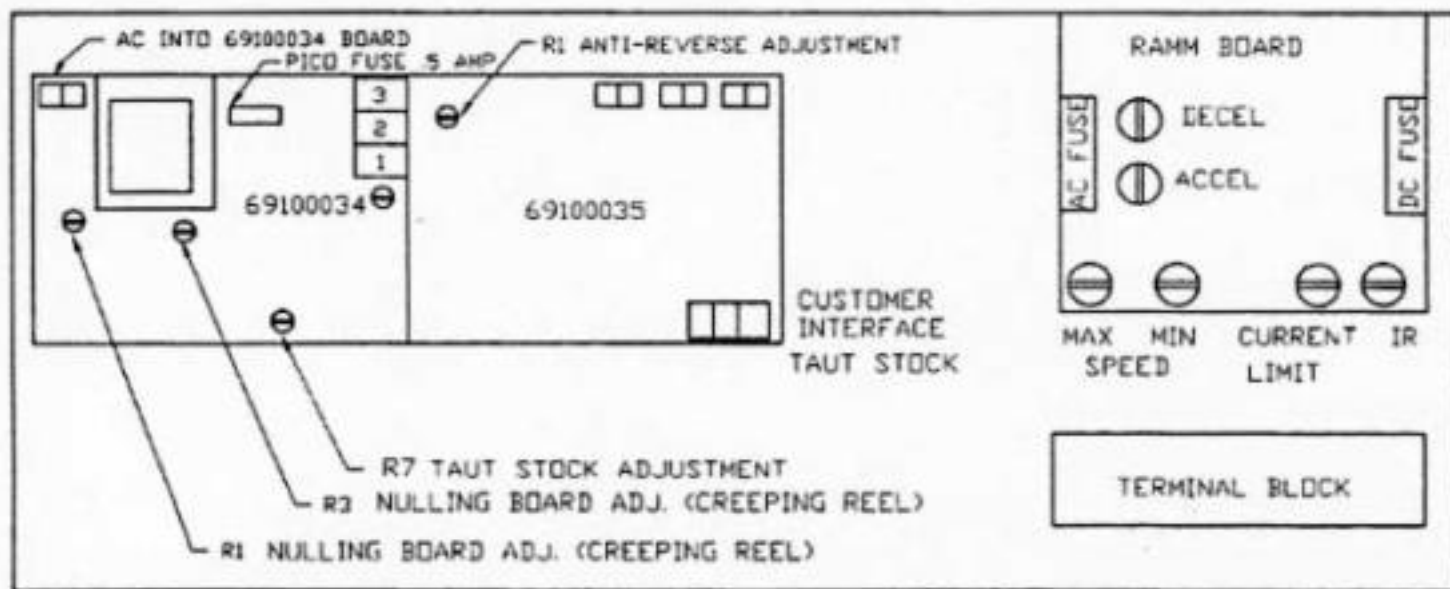

Reel Man 7

CONTROL ARM SETUP & INSTALLATION

Determine the direction of rotation in which the material shall decoil as it leaves the pallet reel. Position the pallet reel in line with the entrance side of the press.

Install the control arm assembly in the control head hub such that the counter weight is pointing toward the turntable. Position the control head and arm and check that it is locked before proceeding

The following sketches will show some basic arrangements of the pallet reel. The choice depends upon such factors as loading ease, clockwise or counter clockwise wound coils, and floor space available.

Locate the proportional control arm and the knurled adjustable knob on the back of the push button unit. Loosen the nut and slide the square drum rod into the slot provided behind the knurled knob, making sure that the drum rod is between the two stops provided. Attach the drum to the drum rod and the counter weight onto the rod provided.

See Drawing (Fig. RA-4)

The following sketches will show some basic arrangements of the pallet reel. Your choice will depend on such factors as: loading ease, clockwise or counter clockwise wound coils, and floor space available

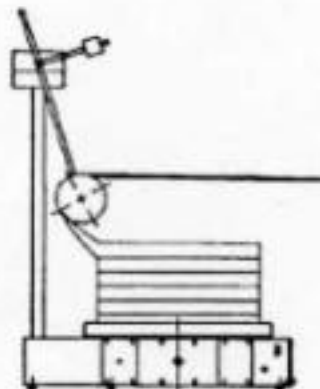
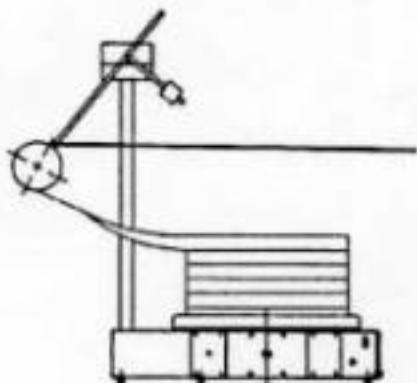
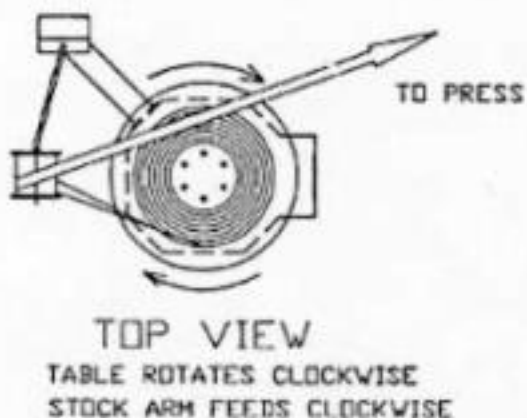
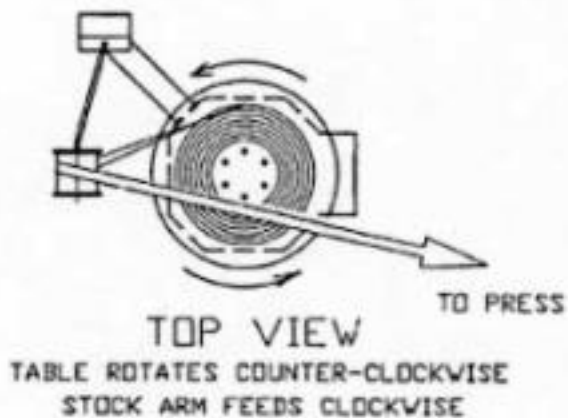
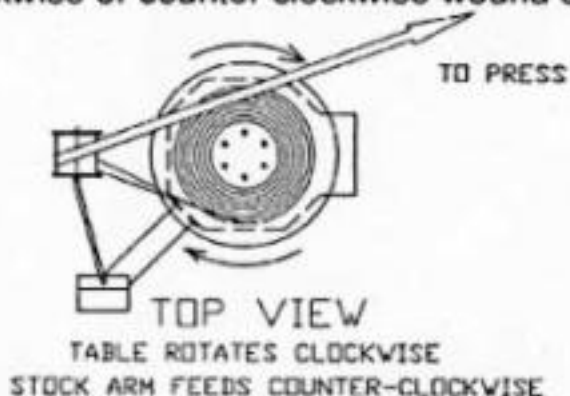
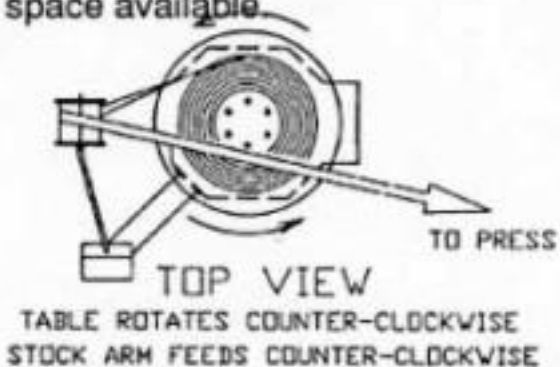

!

DANCER ARM LOOP HEIGHT ADJUSTMENT

Eight different loop sensing arm operating positions are selected manually during set-up. By incrementing the thumbwheel height switch, the zero point of the dancer arm is raised from its rest position to the angle shown (as indicated 0-7). The dancer arm will move from rest position to the angle selected before the pallet reel begins to rotate.

DANCER ARM LOOP RANGE FUNCTION

30 degree— Loop sensing arm travels through a full 30 degree arc to vary turntable rotation speed from slow to full speed as controlled by % speed pot.

20 degree— Loop sensing arm travels through a 20 degree arc to vary turntable speed from slow to full speed as controlled by % speed pot.

10 degree— Loop sensing arm travels through a 10 degree arc to vary turntable rotation speed from slow to full speed as controlled by % speed pot.

5 degree— Only the first 5 degrees of loop sensing arm travel is required to control turntable rotation from slow through full speed as controlled by % speed pot.

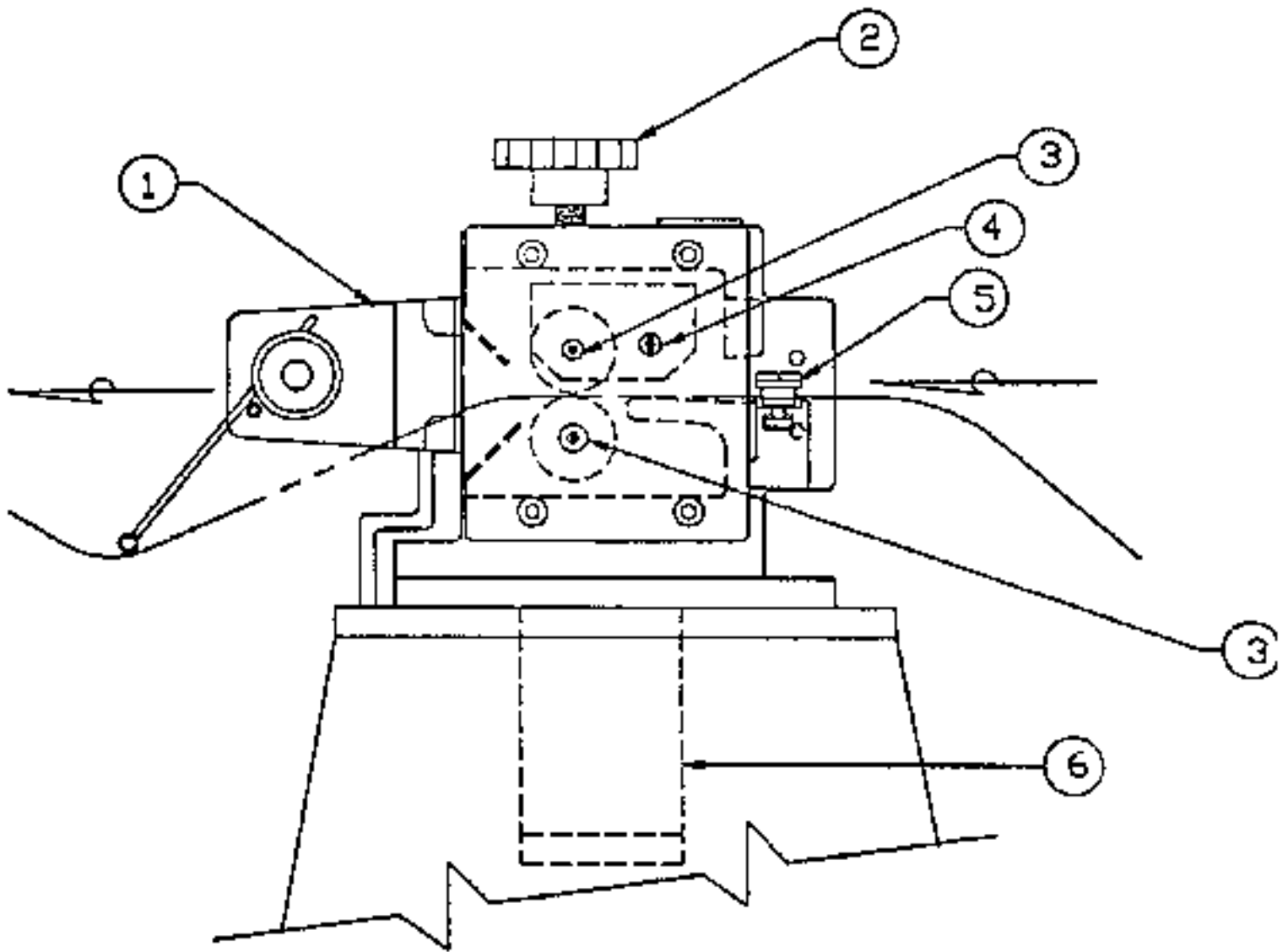

START UP PROCEDURE

Prior to applying power to the machine the operator should review all the controls on the machine. A brief summary of the controls is listed below.

MAIN CONSOLE & CONTROLLER

The main control console & controls are mounted on the end of the raised extended arm of the machine. It was installed to keep the operator clear of the coil plate. Located on the face of the console are seven switches and one potentiometer, which are explained below.

- 1. DIRECTIONAL CONTROL** - The direction control switch selects the direction the pallet reel will rotate, clockwise or counterclockwise.
- 2. % SPEED POT** - The % speed pot adjusts the maximum speed that the pallet reel will rotate and should be set to maintain a constant feed rate.
- 3. ON/OFF SWITCH** - This illuminated switch is the main power switch for the controller. It must be “ON” for the pallet reel to function.
- 4. L↔R SWITCH** - (Stock Arm Direction Switch) - Stock feeds to the press over the table. The Left-Right switch determines from which side of the table the drum is operated. (See Control Arm Setup & Installation).
- 5. RUN/STOP/JOG SELECTOR SWITCH** - The switch selects between Run & Jog. If in Run and the control arm is moved the coil plate will turn. If in Jog, the Jog button has to be depressed for the coil plate to turn.
- 6. JOG BUTTON** - Used for intermittent movement of the coil plate, mainly for

set up. Speed is adjusted on the 69100053 terminal board on the electrical control sub-panel.

7. DANCER ARM LOOP HEIGHT & RANGE ADJUSTMENT -

a. Loop Range - The loop range thumbwheel adjusts the amount of travel the dancer arm will move to provide the full range of speed of the pallet reel.

b. Loop Height - This thumbwheel is used for setting the start position of the control arm. The setting determines when the reel will start turning. Each position will move the operating angle of the arm so that top-to-bottom travel is adjusted to accommodate specific material and loop height requirements.

ELECTRICAL COMPONENT DESCRIPTION

69100034 board—proportional control board

69100035 board—rotational isolation board

69100053 board—terminal board

PC control board (Ramm) - D.C. motor board

TAUT STOCK

The TAUT STOCK feature monitors the loop between the PMD and the external equipment. If the loop gets small enough to possibly cause damage to the PMD, the interface contacts change state and stops the PMD.

If it is desired to monitor the PMD, then the following write up will explain how to connect and adjust this feature.

The **TAUT STOCK** feature is built into the Rapid-Air board #69100035 and wired to external terminals 7-8-9. The terminal #9 is common and from terminal 8 to 9 is a normally closed contact with power on the unit. Terminal 7 to 9 is a normally open contact with power on the unit. These contacts are from “relay 2” chip. See diagram. This relay has to be in place for taut stock to work. There is also a 4 prong post labeled “JUMP” that has to be connected so that relay 2 can be activated. To correctly apply the jumper, locate the post and then locate the plastic 2 prong jumper. Insert the jumper so that the left 2 vertical posts are covered. Once this is in place, the taut stock feature can be tuned.

To tune the taut stock, check that there are no connections on the terminals 7-8 & 9, except those that were factory connected. Attach an OHM meter to terminal 9 & 7 with the meter set to OHMS.

The following is a brief wiring diagram for the taut stock.

3	GRD.
2	10 VDC OUT WITH DANCER ARM DOWN
1	0 VDC OUT WITH DANCER ARM DOWN

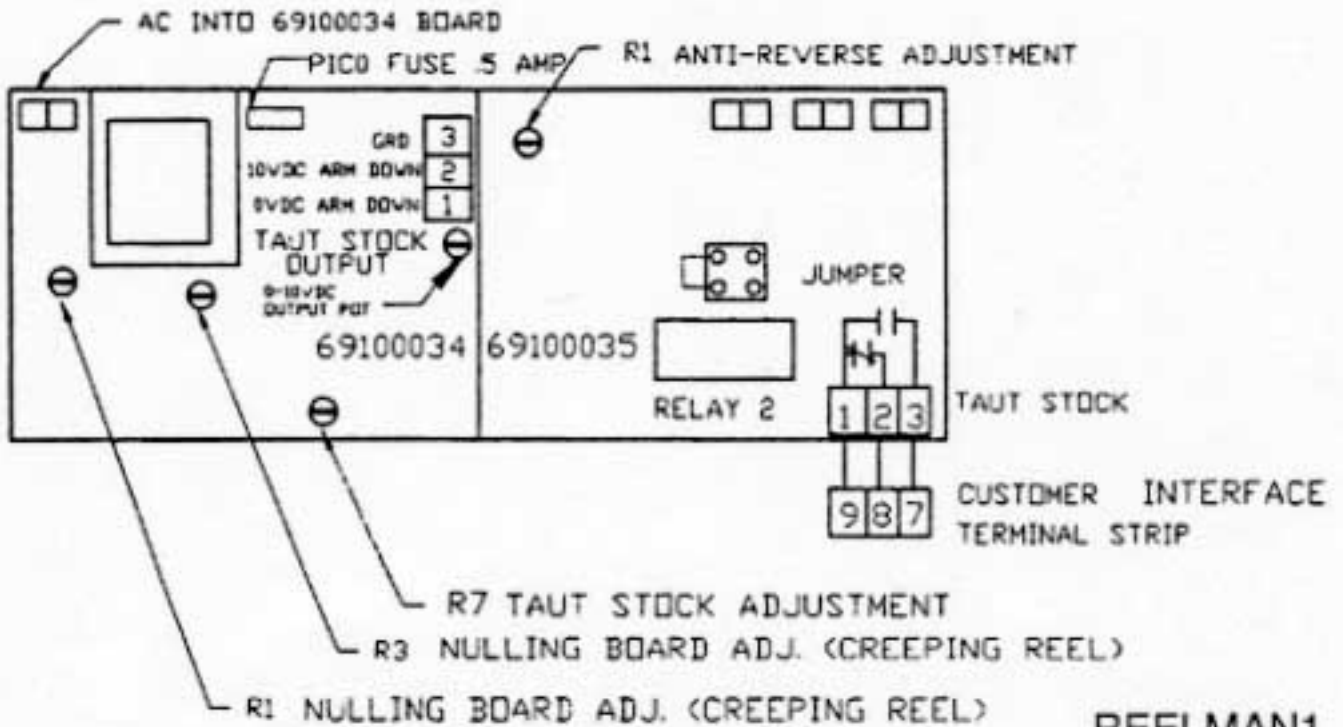

Start the reel and raise the dancer arm so that the reel is running maximum speed. Raise the dancer arm up to a point that the stock would be taut. Hold the dancer arm at this position and adjust the pot R9 of board 69100034 until the contact changes state. Release the dancer arm. The contact should return to normal state. Raise and lower the dancer arm 2 to 3 times to ensure that the contact functions properly. Disconnect the OHM meter and connect the customer interface. CAUTION! The contact rating of the relay is 10VA @ 0.5 amps max.

—

POWER

The system is designed to operate on 120HZ 50/60 power. The unit is provided with a power cord that is connected to a terminal strip located under the pallet reel coil plate. The power is then distributed to the proper control panel. The distributed power is circuit breaker protected and is intended as a power source for the pallet reel and any additional Rapid Air accessory. Plug the main power cord to any grounded 120 VAC, 20 amp receptacle.

PRE OPERATION CHECK

Before placing any material on the turn table, ensure that all functions are in the correct mode for machine operations,

i.e.:

1. Switch “OFF”
2. RUN/STOP/JOG in the “STOP” position
3. Spring loaded control arm has enough spring tension to return to the rest position. (Type “B” arm). Counter balance set to return arm (Type “A” arm).
4. Lock control box swivel mechanism into position
5. Rotation direction switch agrees with the decoiling direction of the material on the pallet that is ready to be loaded onto the pallet reel
6. Loop range at maximum angle (#3 on thumbwheel)
7. % speed at 30% to 50%. This may need to be increased or decreased to keep up with press demand when the unit is in operation.

START UP AND RUN CHECK

1. Switch “ON”
2. RUN/STOP/JOG - “RUN”
3. Slowly push (rotate) the control arm toward the turntable to start the rotation.
 - A. If the table turns in the wrong direction, turn power switch “OFF” and reverse the rotation direction switch. Then turn switch “ON”.
 - B. The turntable speed should increase as the control arm is moved toward the table.

OPERATION

1. Place the coiled stock on the turn table. Center the material on the turn table so the coils are concentric with the table.
2. Rotate the table slowly by pushing the control arm toward the turn table. Unwind the first coil until the material can be threaded around the roller and back toward the press. The control arm and turn table will now operate automatically.
3. Slowly walk the material to the press. An alternative means of moving the material toward the press is to turn the RUN/STOP/JOG switch to jog and the push the jog button. This may be a preferred method since this function overrides the control arm that may not be properly set at this time. See optional equipment.
4. RUN/STOP/JOG - “STOP”
5. Adjust the roller angle so that the material makes full contact on the spool.

This should be done after the material has been started through the die so final alignment has been achieved.

6. Adjust the height on the control arm.

7. Adjust the spring pressure on type “B” or adjust counter balance weight on type “A” control arm to just offset the effect of the material loop so the control arm will go back to the starting (rest) position when the press is not demanding material. After this has been completed, turn TRUN/STOP/JOG to “RUN”. You are now ready to run.

CONTROL ADJUSTMENTS

The PMD has been fully tested and set for optimum performance at the factory. Although this setting would normally be sufficient for most installations, there are some cases where readjustments are needed for a smoother operation. Rapid Air has provided 2 pots on the DC control board (RAMM) for fine tuning of the acceleration and deceleration ramps. CAUTION!! Making these adjustments should be done by qualified personnel using a plastic or insulated screw driver.

STANDARD EQUIPMENT

—
Spring Loaded ID keeper:

- A. Used to contain the ID of the coil from springing inward and falling down into the coil below.
- B. Also used to keep coil in place when the diameter becomes very small, otherwise the coil may slide off the unit at the smallest diameter.
- C. The overall length of the ID keeper can be cut off to suit. Depending on the majority of coil ID ranges used.

OPTIONAL EQUIPMENT

—

The remote jog consists of approx. 10 feet of cord to which a jog button is attached via the connector on the control box. This can be used instead of manually jogging the pallet reel at the control box. The cord plugs directly into an existing external connector provided on the control box arm. This feature allows the operator to move about more freely while threading the unit.

MACHINE MAINTENANCE

-
1. Gear Box—The gear box has a four quart capacity and is filled with Mobil #SHE-630 synthetic oil. The oil level should be checked monthly and filled as needed.

2. Motor—The DC drive motor commutator brushes should be checked after every 1500 hours of use. When the brushes are worn down to 5/8” or less, they should be replaced with new brushes.

TROUBLE SHOOTING GUIDE

MAIN SWITCH ON BUT NOT LIT

1. CB tripped
 - a. Reset CB
2. Unit not plugged into main power.
 - a. Plug into main power source.
3. No power in incoming line.
 - a. Check outlet.
 - b. Check power cord.
4. Loose wiring
 - a. Check terminals and connections.

MOTOR CREEPS IN STOP POSITION

1. R1 & R3 pot on 69100034 board not correctly adjusted.
 - a. Readjust pots so table stops. Call factory.

UNIT TURNS BUT WON'T JOG

1. Selector switch not in jog position.
 - a. Select jog.
2. Jog pot on 69100053 board not adjusted correctly.
 - a. Adjust pot. Call factory.
3. Maximum speed pot on Ramm board set too low.
 - a. Adjust pot.

UNIT ON BUT MOTOR WON'T RUN. (ARMATURE VOLTAGE PRESENT ON RAMM BOARD)

1. Check TB-4 of 69100035 board. Terminal 1&2.
 - a. If voltage not present, replace 69100035 board. Call factory.
2. Check motor wiring
 - a. Replace motor cord or correct motor wiring. Call factory.
3. Check motor

- a. Worn brushes or motor defective. Call factory.

NOTE: Refer to drawing RA-2 for location of components, sequence check form Ramm board to motor.

UNIT ON BUT MOTOR WON'T RUN. (NO ARMATURE VOLTAGE ON RAMM BOARD)

1. Selector switch not in run position.
 - a. Turn selector switch to run position.
2. Transition plug not installed.
 - a. If not using E control, install transition plug supplied with unit.
3. Thumbwheel height setting too high.
 - a. Set height setting to "0".
4. Percent speed pot set too low.
 - a. Adjust percent speed pot to 100%.
5. Fuses blown.
 - a. Check fuses on DC drive board.

6. No AC voltage at DC drive board.
 - a. Check wiring.

7. Check Signal voltage between P2 to I2 on DC drive while moving dancer arm.

0-6 VDC—Ramm

0-9 VDC—Regen Drive
 - a. If there is a signal, check continuity between I1 & I2.

If continuity, replace 69100035 board or call factory.

If no continuity, replace D.C. drive or call factory.

8. Check line voltage input of 69100034 board, 120 VAC, TB-1
 - a. Check wiring. Call factory.

9. Check pico fuse 69100034 board (f1).
 - a. Replace fuse—call factory.

10. Check for 0—12 VDC between pin #1 (+V) and pin #2 (GND) of panduit connector TC3 on board #69100034.
 - a. If no voltage present call factory.

11. Check for DC voltage between pin #6 (V0) and pin #2 GND of panduit connector TC3, on board #69100034, while moving the dancer arm from minimum to maximum position.
 - a. If voltage is present, turn power off and check the ribbon cable

connections between panduit connector #TC3 of 69100034 board and panduit connector #TC3 of 69100035 board and panduit connector #PT3 of 69100053 board. This should be a continuity check for tight connections. Call factory for assistance.

b. If voltage is not present move on to step 12.

12. Check voltage between pin #2 of TB-2 & pin #5 of TB-7 on 69100053 board while moving the dancer arm from minimum to maximum position.

a. If voltage varies 2.5-4 volt from minimum to maximum position, the dancer arm pot is OK, but the 69100034 board could be defective. Call factory.

b. If voltage does not vary when moving the dancer arm from minimum to maximum position—call the factory for assistance.

Remove the access cover of the control arm and route the electrical wires from the base into the electrical control area. Attach the wires to the terminals provided.

See fig. below.

The PMD can be ordered with 120 vac 1 phase input or 240 1 phase input.

If using 120 vac 1 phase input. Terminal 4 & 5 will not be used and cannot be used unless the Ramm is changed to a 220 volt controller.

If using 220 vac 1 phase input. Wire as indicated by drawing fig. RA-2. This unit cannot be used with 120 vac 1 phase input unless the Ramm Board is changed to a 120 volt controller.

See fig. RA-2.

RAPID-AIR CORPORATION

RAMM

SOLID STATE

DC MOTOR

SPEED CONTROL

SAFETY WARNING—PLEASE READ CAREFULLY

This product should be installed and serviced by a qualified technician, electrician or electrical maintenance personnel familiar with its operation and the hazards involved. Proper installation (see instruction information which accompanies product), which includes wiring, mounting in proper enclosure, fusing or other overcurrent protection and grounding, can reduce the chance of electrical shocks, fires or explosion in this product or products used with this product, such as

electric motors, switches, coils solenoids and/or relays. Eye protection must be worn when working with control under power. This product is constructed of materials (plastics, metals, carbon, silicon, etc.) which may be a potential hazard. Individual material safety data sheets (MSDS) are available upon request. Proper shielding, grounding and filtering of this product can reduce the emission of radio frequency interference (RFI) which may adversely affect sensitive electronic equipment. If information is required on this product, contact our factory. It is the responsibility of the ultimate user of this product to read and comply with this safety warning. (SW effective 1/89)

*****IMPORTANT*****

**YOU MUST READ THESE INSTRUCTIONS BEFORE OPERATING
CONTROL**

1. Be sure AC line voltage corresponds to control voltage.
2. Install the correct Plug-In Horsepower Resistor according to armature voltage and motor horsepower.
3. Recheck connections: AC line to L1 and L2; armature to A+ and A- and field (Shunt motors only to F+ and F-.) (Note: If motor runs in improper direction, interchange armature leads.)
4. Install proper AC line fuse and armature fuse as required.

5. Nominal trimpot settings are as follows (expressed in % of full CW rotation):

TABLE 1: NOMINAL TRIMPOT SETTINGS

MIN (minimum speed): 15% CL (current limit/torque): 65%

MAX (maximum speed): 65% ACCEL (acceleration start): 20%

IR (IR compensation): 25% DECEL (deceleration stop): 20%

PLUG IN HORSEPOWER RESISTOR

A Plug-In Horsepower Resistor must be installed to match the RAMM to the motor horsepower and voltage. See table 2 for the correct value. Plug-In Horsepower Resistors are stocked by your distributor.

TABLE 2. PLUG IN HORSEPOWER RESISTOR CHART*

MOTOR HORSEPOWER RANGE **		Plug-in Horsepower Resistor Resistance Value (ohms)	Rapid-Air P/N
Armature Voltage 90-130 VDC	Armature Voltage 180 VDC		
1/4	1/2	.05	69100529
1/2	1	.025	69100530
3/4	1-1/2	.015	69100534
1***	2***	.01	69100531

* Motor horsepower and armature voltage must be specified when ordering so that proper resistor will be supplied.

** For overlapping motor horsepower range use lower value Plug-In Horsepower Resistor.

*** Auxiliary heatsink must be used to achieve HP rating.

INTRODUCTION

The **RAMM** Full Wave Solid State DC Motor Speed Control represents the latest state of the art design achievable through modern technology.

Features Include:

Integrated Circuitry

Used to control and amplify command and reference levels with both closed and open loop feedback to provide superior motor regulation. (Speed changes due to load, line voltage, or temperature variations are held to minimum levels).

High Quality Components

Selected and tested for proven dependability.

Transient Protection

Used to prevent failure of the power bridge circuit caused by voltage spikes on the AC line.

High Reliability

When used in accordance with instructions in this manual, the RAMM will provide years of trouble free operation.

A. Initial Setup and Wiring

i. General Instructions

1. Install proper size Plug-In Horsepower Resistor. (see table 2)
2. The **RAMM** can be connected to a standard 120V or 240V 50/60 Hz AC line (be sure the AC input voltage corresponds to the control voltage rating and the motor rating). (e.g. 90-130 VDC motor on 120VAC and 180 VDC motor on 240 VAC)
3. Follow the recommended supply wire sizes as per table 3.
4. Follow the NEC and other electrical codes that apply.

CAUTION: SEPARATE BRANCH PROTECTION MUST BE PROVIDED ON 240V CIRCUITS.

5. Connect control in accordance to connection diagram.

TABLE 3. MINIMUM SUPPLY WIRE SIZE REQUIREMENTS

MAX. MOTOR AMPS (DC AMPS)	MAX. MOTOR HP 90V	MAX. MOTOR HP 180V	MINIMUM WIRE SIZE (AWG) Cu only)	
			MAX. MOTOR RUN	MAX. MOTOR RUN
6.0	1/2	1	16	14
12.0	1	2	14	12*
16.0	1 1/2	3	12	12

*Maximum recommended wire size

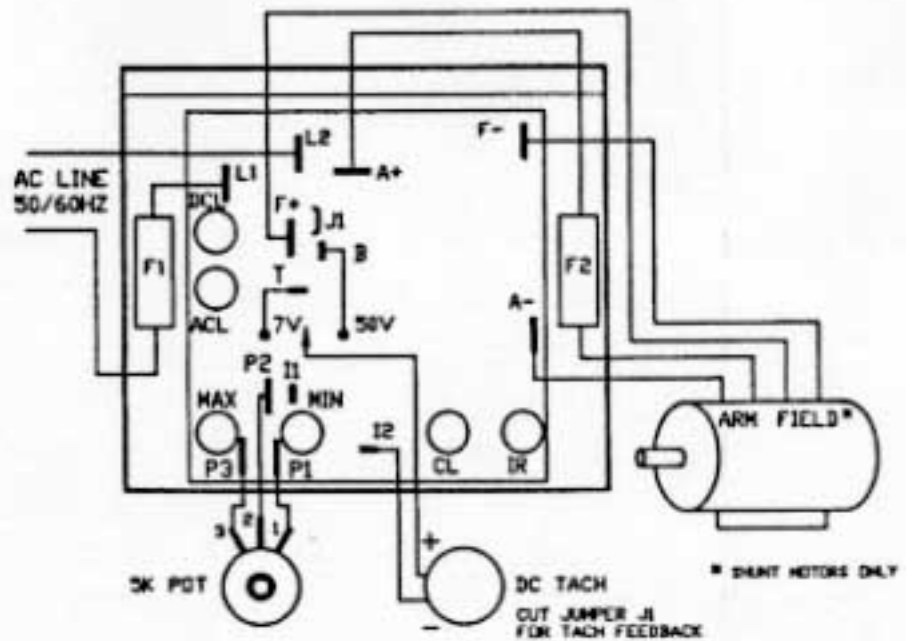

Fig. 1. Basic RAMM Connection Diagram

B. VOLTAGE FOLLOWING. All models can be controlled with an isolated analog reference voltage (0-6VDC) in lieu of the main speed potentiometer. The voltage is connected to P2 (+) and F-. The control output voltage will linearly follow the input voltage. The source impedance of the input should be 10K ohms or less. The Min trimpot can be used to provide an offset speed. If an offset is not required adjust the Min to 0+ or 0- speed as desired. The Max trimpot is rendered inoperative in the voltage following mode. Use auxiliary trimpot to limit the control range. If the input signal is not isolated, or is a current signal (4-20ma), the RASI240D) Signal Isolator must be used. It will allow direct connection to process controllers and microprocessors.

C. FUSING. The **RAMM** has provision for a built in AC line fuse and armature fuse. The AC line fuse protects the control against catastrophic failure— if the fuse blows, the control is miswired, the motor is shorted or grounded, or the **RAMM** control is defective. The armature fuse provides overload protection for the motor and control. Choose the proper size armature fuse by multiplying the maximum DC motor amps by 1.7. On domestic 240 Volt AC lines, separate branch circuit protection for each line must be used. All fuses should be normal blow ceramic 3AG or ABC or equivalent.

CAUTION: Do not bundle potentiometer connections (P1, P2, P3) and inhibit connections (I1, I2) with AC line or motor wires.

CATUION: 1. The voltage feeding P2 and F– must be isolated from the AC line.

Do not ground P2 or F– to set up a zero ground reference.

2. Do not bundle signal wires to P2 and F– with AC line motor connections. If signal wires are over 18”, use shielded cables.

1. AC Line Fuse is chosen according to the maximum rating of the control:

12 AMP fuse for all motors up to 3/4 HP-90V and 1 1/2 HP-180VDC.

25 AMP fuse for all motors 1 and 1 1/2 HP-90v and 2 and 3 HP-180VDC.

(Use Buss ABC, Littlefuse 326 ceramic fuse or equivalent.)

2. Armature Fuse can be chosen in accordance with the fuse chart. Note: The armature fuse is calculated based on the approximate full load DC current rating of the motor times a from factor of 1.5. If motor has characteristics not consistent with these approximations, a different fuse value may have to be used. Fuses are available from your distributor.

TABLE 4. ARMATURE FUSE CHART

90VDC MOTOR	180VDC MOTOR	APPROX. DC MOTOR CURRENT (AMPS)	FUSE RATING (AC AMPS)
HORSEPOWER			
1/4	1/2	2.5	4
1/2	1	5.0	8
3/4	1 1/2	7.5	12*
1	2	10.0	15
1 1/2	3	15.0	25*
*Also used as AC line Fuse.			

ADJUSTMENTS AND CONTROL FUNCTIONS

Warning: If adjustments are made under power, insulated adjustment tools

must be used and eye protection must be worn.

The **RAMM** has been factory adjusted to provide 0-full speed using the speed control knob. Minimum and Maximum speed trimpots are provided to change the speed from other than 0-full speed. The Acceleration (ACCEL) trimpot is provided to allow for a smooth start over an adjustable time period each time the AC power is applied or the speed pot is rotated. The DECEL trimpot controls the amount of ramp-down when the speed pot is adjusted to a lower speed. The Current Limit (CL, or torque output) adjustment is factory set to approximately 1.5 times the motor rating. The IR Compensation (IR) is factory adjusted to provide excellent motor regulation under normal operation.

The following procedure, presented in order of adjustment sequence, should be used when readjusting all trimpot functions.

Fig 2. ACCEL/DECEL

TRIMPOT ADJUSTMENT

Fig 2. ACCEL/DECEL TRIMPOT ADJUSTMENT

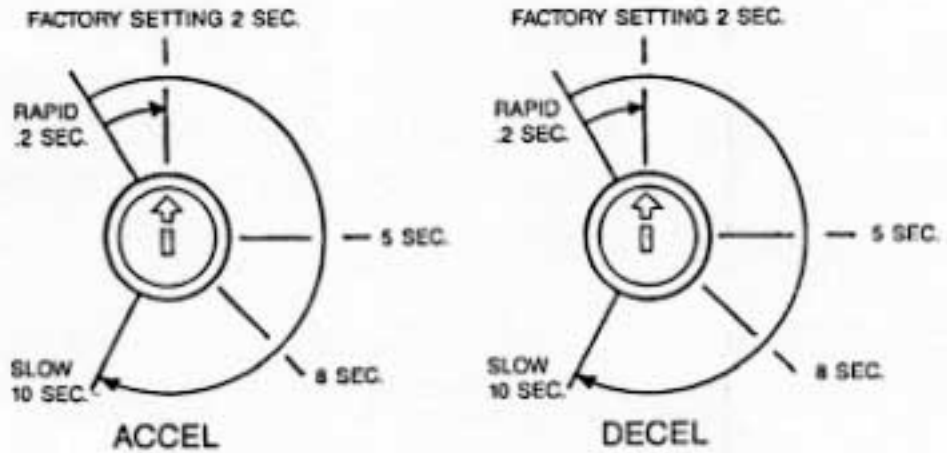

A. Acceleration Start. The ACCEL is factory set at approximately .2 seconds. To readjust to different times, set the knob to the desired position as indicated in Fig 2.

B. Deceleration. The DECEL is factory set to provide a ramp-down time of .2 seconds. To change the ramp-down time, adjust the DECEL trimpot as indicated in Fig 2.

C. Minimum Speed Adjustment. If a higher than zero minimum speed is desired, readjust the minimum speed by turning the speed control knob to zero setting (full CCW position). Then adjust the Min. Speed Trimpot to the desired setting.

D. Maximum Speed Adjustment. Turn Speed Control Knob to full speed (maximum CW position). Adjust max. speed trimpot to new desired setting.

E. Current Limit (CL/Torque Adjustment). CL circuitry is provided to protect the motor and control against overloads. The CL also limits the inrush current to safe level during startup. The CL is factory set to approximately 1.5 times the full load rating of the motor. (CL trimpot is nominally set to approximately 65% of full CW rotation).

NOTE: In order for the IR comp and CL trimpot settings to be correct, the proper Plug-in

Horsepower Resistor must be installed for the particular motor and input volt age

being used. Do not attempt to change the settings of the trimpots unless absolutely

necessary since they are factory adjusted to near optimum settings.

NOTE: The min. speed adjustment will affect the max. speed setting. Therefore, it is

necessary to readjust the max. speed after the min. speed is adjusted.

NOTE: Do not attempt to adjust the max. speed above the rated motor RPM since unstable motor operation may occur. For moderate changes in the max. speed, there will be a slight effect on the min. speed setting.

To set the CL to factory specifications adjust as follows:

1. Set speed control knob at approximately 30-50% CW rotation.

Set CL trimpot to full CCW position.

2. Connect a DC ammeter in series with the armature lead.
3. Lock shaft of motor (be sure CL pot is in full CCW position).

Apply power and rotate CL pot CW slowly until DC ammeter reads 1.5 times motor

rating (do not exceed 2 times motor rating, Max. CW position.)

F. IR Compensation Adjustment. IR compensation is provided to substantially improve load regulation. If the load presented to the motor does not vary substantially, the IR adjustment may be set at a minimum level (approximately 1/4 of full setting). The control is factory adjusted to approximately 3% regulation. If superior performance is desired (less than 1% speed change of base speed from 0 to full load), then the IR comp. Should be adjusted as follows:

1. Set IR comp. trimpot at approximately 25% of CW rotation. Run motor unloaded at approximately 1/3 speed and record RPM.
2. Run motor with maximum load and adjust IR comp. trimpot so that the motor speed under load equals the unloaded speed per step 1.
3. Remove load and recheck unloaded RPM. If unloaded RPM has shifted, repeat procedure for more exact regulation.

The **RAMM** is now compensated to provide minimal speed change under large variations of applied load.

NOTE: If only an AC ammeter is available, it can be installed in series with the AC line.

Follow above instructions; however, set AC amperage at .75 times motor rating.

NOTES: 1. Excessive IR comp. will cause control to become unstable, which causes

motor cogging.

2. For tach feedback applications the IR comp can be set to minimum rotation

(full CCW).

LIMITED WARRANTY—RAMM 125, 225, 225D

For a period of one (1) year from date of original purchase Rapid-Air Corporation will repair or replace without charge devices which our

examination proves to be defective in material or workmanship. This warranty is valid if the unit has not been tampered with by unauthorized persons, misused, abused or improperly installed and has been used in accordance with the instructions and/or ratings supplied. The foregoing is in lieu of any other warranty or guarantee expressed or implied, and we are not responsible for any expense (including installation and removal), inconvenience, or consequential damage, including injury to any person, caused by items of our manufacture and/or sale. Some states do not allow certain exclusions or limitations found in this warranty so that they may not apply to you. In any event, Rapid-Air Corporation's total liability, under all circumstances, shall not exceed the full purchase price of this unit.

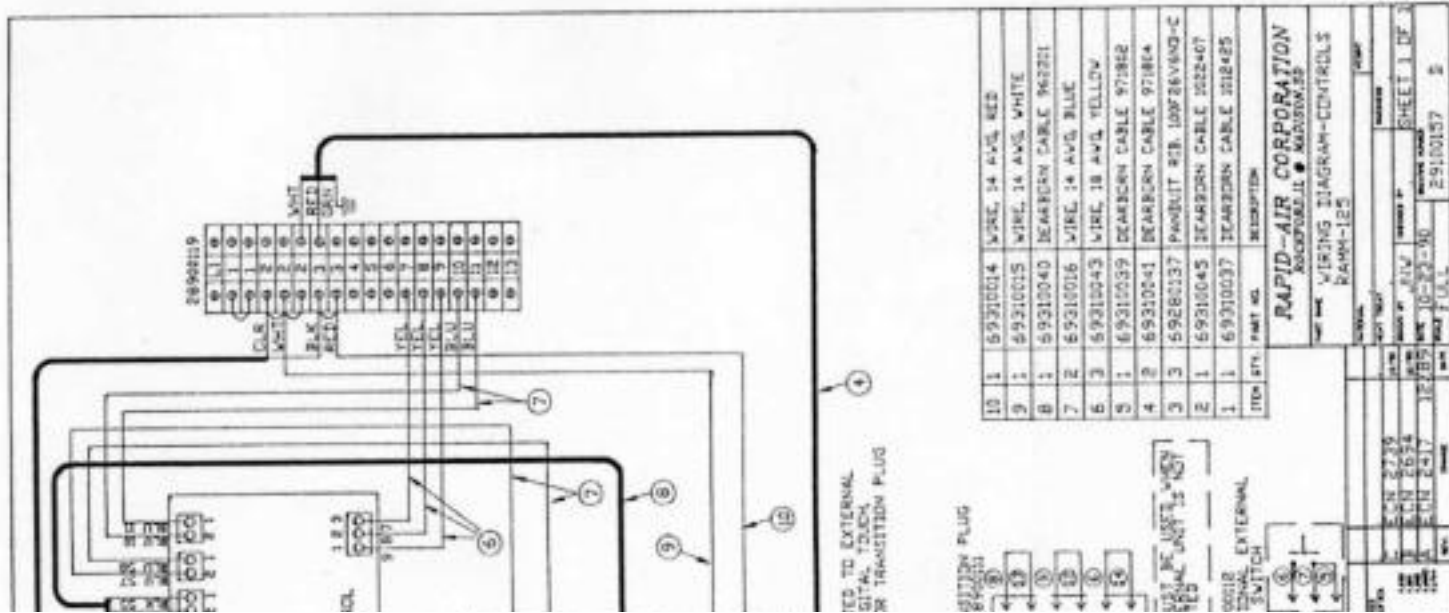

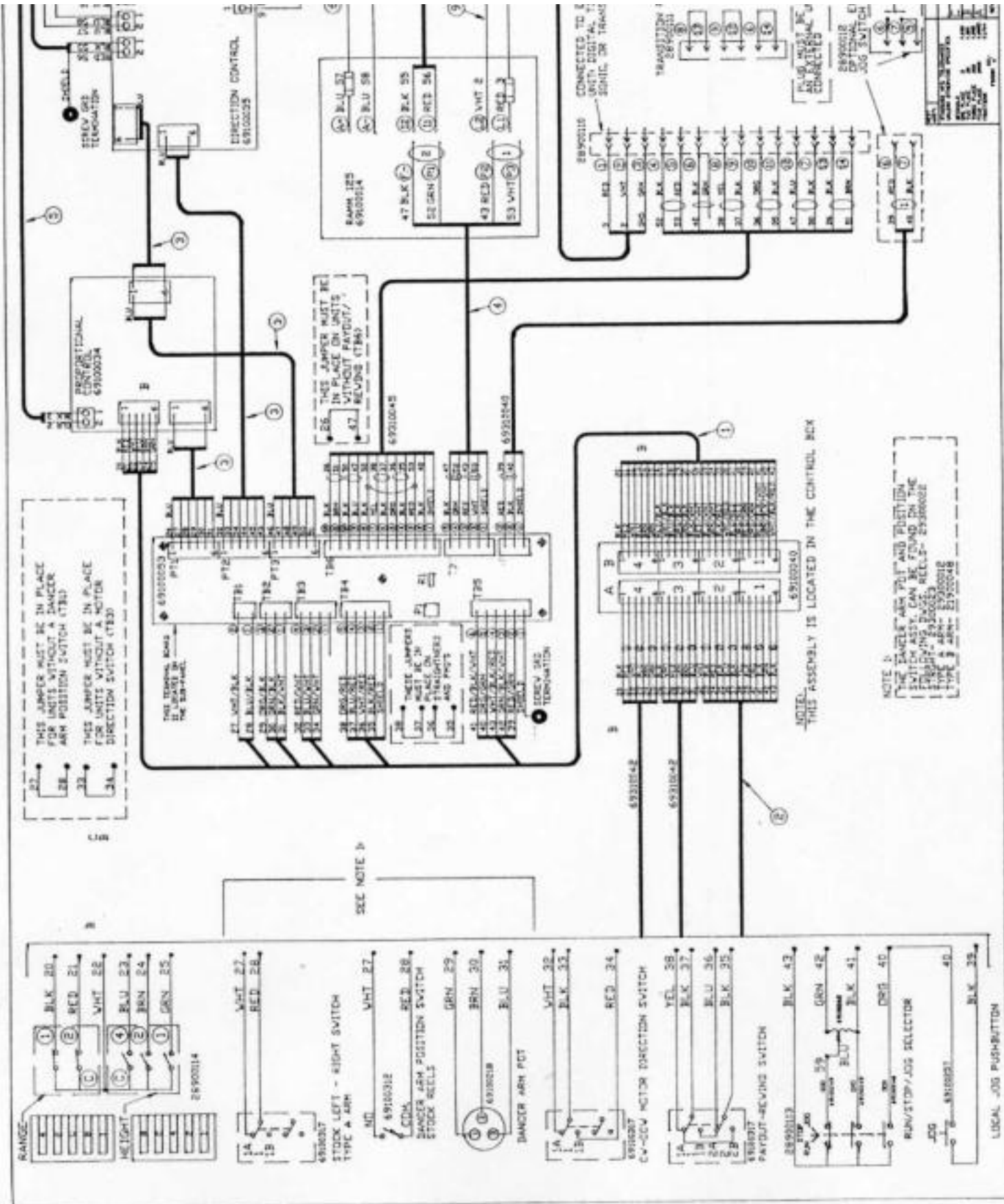

6.BLUE WIRE - ALL DC WIRES.
INTERLOCK WIRES.
ATLANTA

ATION
.SD

HEIGHT

MSM

B

* WIRE COLOR CODE
 1. BLACK WIRE - ALL 220VAC 1 PHASE WIRES.
 2. RED WIRE - ALL 120VAC LEFT HAND COMMON AC CONTROL CIRCUITS.
 3. WHITE WIRE - ALL 120VAC RIGHT HAND COMMON, GROUNDED CIRCUIT CONDUCTORS.
 4. GREEN WIRE - ALL GROUND WIRES.
 5. YELLOW WIRE - ALL CUSTOMER INTERLOCK WIRES.

REFER TO SHEET 2 OF 2 FOR TERMINAL CONNECTIONS

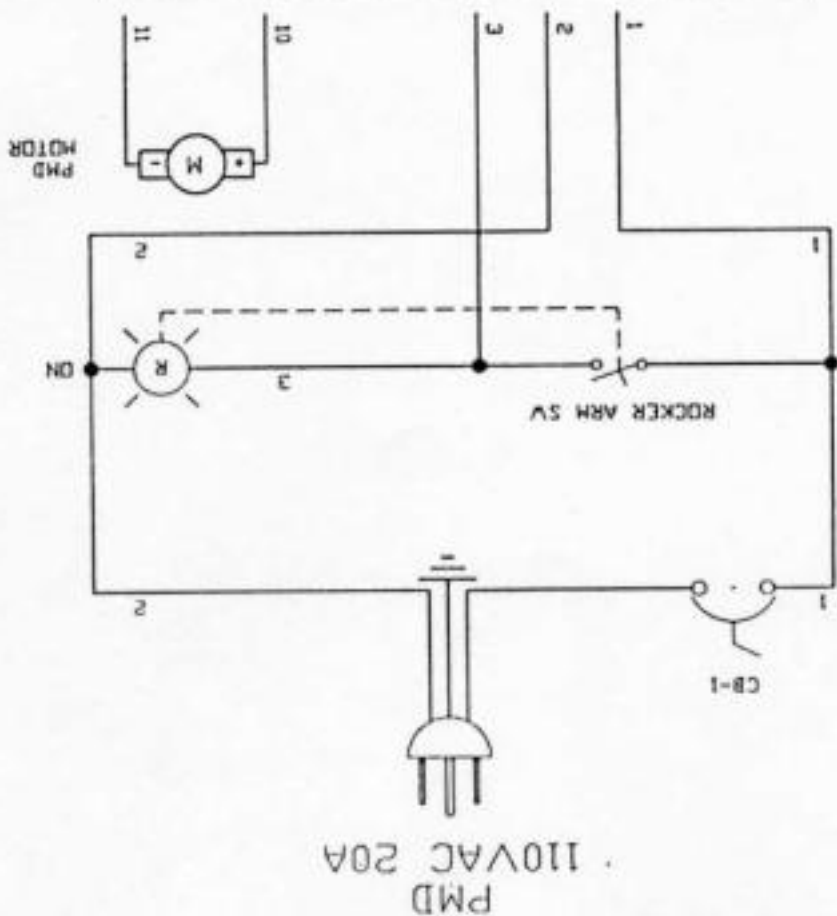

RAPID-AIR CORPORATION
 ROCKFORD, IL • MADISON, SD

PART NAME: 110 VAC 1 PH
 PMD

MATERIAL: _____ HEAT TREAT: _____ HARDNESS: _____

DRAWN BY: GSM CHECKED BY: _____ FINAL FINISH: _____

DATE: 6-5-90 DRAWING NUMBER: 85500179

SCALE: FULL

REV.	DATE	DESCRIPTION
1	11/84	FINISH ✓
2	12/05	
3	12/05	
4	12/05	
5	12/05	

STANDARD MFG. TOLERANCES UNLESS OTHERWISE SPECIFIED

DECIMALS: 1.230
 ONE PLACE: .2
 TWO PLACE: .00
 THREE PLACE: .000
 FOUR PLACE: .0000
 FRACTIONS: 63